



ISO Cylinder Series C95



ø32, ø40, ø50, ø63, ø80, ø100

Dimensions conform to ISO 6431, VDMA 24562, CETOP RP43P.



CJ1
CJP
CJ2
CM2
C85
CG1
MB
C95
CA1
CS1

Variations

Series	Action	Style		Basic	Standard variations		Made to Order Heat resist.	Bore (mm)	Page
					Built-in magnet	Stainless steel rod			
Standard Series C95 	Double acting	Single rod	Non-lube	•	•	•	•	32, 40 50, 63 80, 100	1.8-4
		Double rod	Non-lube	•	•	•	•		
Non-rotating rod Series C95K 	Double acting	Single rod	Non-lube	•	•	(Standard)	•	32, 40 50, 63 80, 100	1.8-10
		Double rod	Non-lube	•	•	(Standard)	•		

ISO Cylinder/Standard: Double Acting

Series C95

ø32, ø40, ø50, ø63, ø80, ø100

How to Order

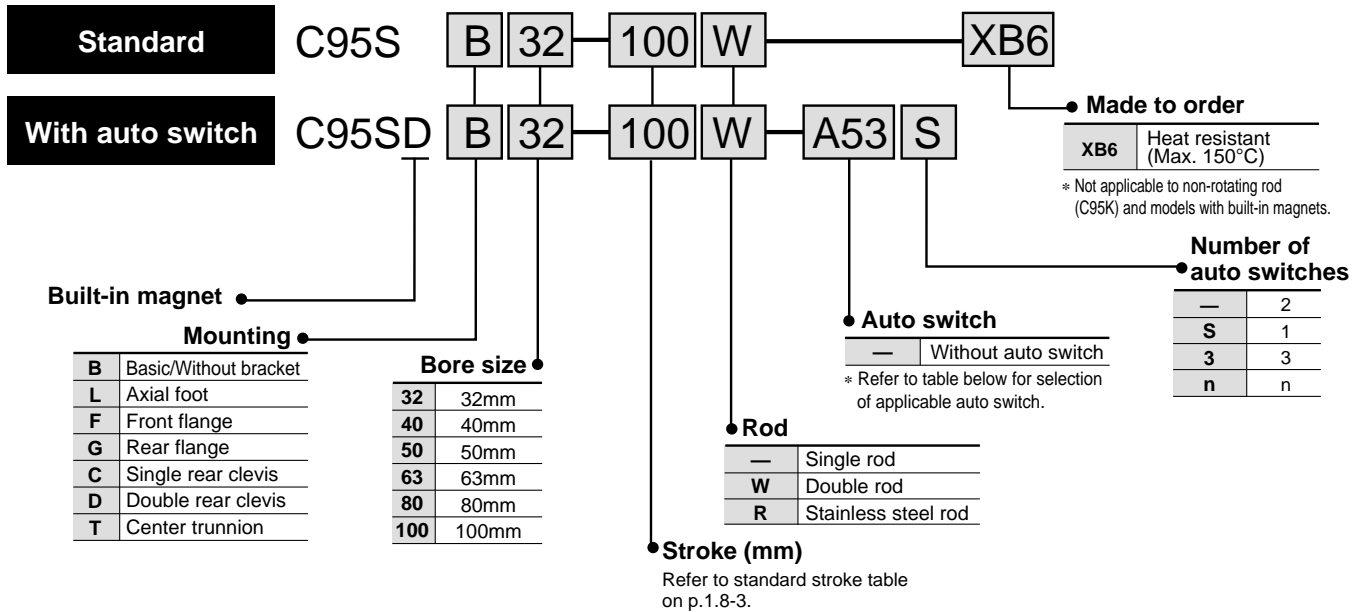

Applicable Auto Switches/Tie rod mounting

Style	Special function	Electrical entry	Indicator	Load voltage			Auto switch model	Lead wire (m)*			Applicable load				
				Wiring (Output)	DC	AC		0.5 (—)	3 (L)	5 (Z)					
Reed switch	—	Grommet	Yes	3 wire (Output) (Equiv. to NPN)	—	5V	—	A56	●	●	—	IC			
					—	12V	—	A53	●	●	●	—			
					5V,12V	100V,200V	A54	●	●	●	—				
					24V	5V,12V	—	A67	●	●	—	IC			
					—	12V	200V or less	A64	●	●	—	—			
Diagnosis indication (2 color)	—	—	Yes	—	—	—	A59W	●	●	—	—				
Solid state switch	—	Grommet	Yes	3 wire (NPN)	24V	5V,12V	—	F59	●	●	○	IC			
								3 wire (PNP)	—	—	F5P	●	●	○	—
								2 wire	—	100V,200V	J51	●	●	○	—
								—	12V	—	J59	●	●	○	—
								3 wire (NPN)	—	5V,12V	F59W	●	●	○	IC
								3 wire (PNP)	—	—	F5PW	●	●	○	—
								2 wire	24V	12V	J59W	●	●	○	—
								—	—	—	F5BA	—	●	○	—
								3 wire (NPN)	—	5V,12V	F5NT	—	●	○	IC
								4 wire (NPN)	—	—	F59F	●	●	○	—
—	—	—	F5LF	●	●	○	—								

* Lead wire length 0.5m..... — (Example: A53)
3m..... L (Example: A53L)
5m..... Z (Example: A53Z)

○: Manufactured upon receipt of order.

Mounting Bracket Part No.

Bore size	ø32	ø40	ø50	ø63	ø80	ø100
Foot ⁽¹⁾	L5032	L5040	L5050	L5063	L5080	L5100
Flange	F5032	F5040	F5050	F5063	F5080	F5100
Single rear clevis	C5032	C5040	C5050	C5063	C5080	C5100
Double rear clevis	D5032	D5040	D5050	D5063	D5080	D5100

Note 1) Two foot brackets required for one cylinder.

Note 2) Accessories for each mounting bracket are as follows.

Foot, Flange, Single clevis: Mounting bolts

Double rear clevis: Clevis pin

Auto Switch Mounting Bracket Part No.

Bore size	ø32, ø40	ø50, ø63	ø80, ø100
Mounting bracket	BT-03	BT-05	BT-06

ISO Cylinder/Standard: Double Acting *Series C95*

Specifications



JIS Symbol
Double acting

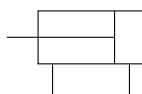

Minimum Strokes for Auto Switch Mounting

Refer to p.1.8-12 for "Minimum Strokes for Auto Switch Mounting".

Bore size	ø32	ø40	ø50	ø63	ø80	ø100
Action	Double acting					
Fluid	Air					
Proof pressure	1.5MPa					
Max. operating pressure	1.0MPa					
Min. operating pressure	0.05MPa					
Ambient and fluid temperature	Without magnet -10 to 70°C (No freezing)					
	With magnet -10 to 60°C (No freezing)					
Lubrication	Not required (Non-lube)					
Operating piston speed	50 to 1000mm/s					
Allowable stroke tolerance	to 250: $+1.0_0$, 251 to 1000: $+1.4_0$, 1001 to 1500: $+1.8_0$					
Cushion	Both ends (Air cushion) ⁽¹⁾					
Thread tolerance	JIS class 2					
Port size	G1/8	G1/4	G1/4	G3/8	G3/8	G1/2
Mounting	Basic, axial foot, front flange, rear flange, single rear clevis, double rear clevis, center trunnion					

Note 1) When requesting a cylinder without air cushion, cylinder utilizes rubber bumpers which increase cylinder's overall length.

Standard Stroke

Bore size (mm)	Standard stroke (mm)	Max. * stroke
32	25, 50, 80, 100, 125, 160, 200, 250, 320, 400, 500	700
40	25, 50, 80, 100, 125, 160, 200, 250, 320, 400, 500	800
50	25, 50, 80, 100, 125, 160, 200, 250, 320, 400, 500, 600	1200
63	25, 50, 80, 100, 125, 160, 200, 250, 320, 400, 500, 600	1200
80	25, 50, 80, 100, 125, 160, 200, 250, 320, 400, 500, 600	1400
100	25, 50, 80, 100, 125, 160, 200, 250, 320, 400, 500, 600	1500

Intermediate strokes are available.

* Consult SMC for longer strokes.

Applicable Auto Switches

Style	Auto switch model	Electrical entry (function)
Reed switch	D-A5□/A6□	Grommet
	D-A59W	Grommet (2 color indication)
Solid state switch	D-F5□/J5□	Grommet
	D-F5□W/J59W□	Grommet (2 color indication)
	D-F5BA	Grommet (2 color, Water resistant)
	D-F5□F	Grommet (2 color, diagnosis output)
	D-F5NT	Grommet (Timer)

Accessories

Mounting		Basic	Foot	Front flange	Rear flange	Single rear clevis	Double rear clevis	Center trunnion
Standard	Rod end nut	●	●	●	●	●	●	●
	Clevis pin	—	—	—	—	—	●	—
Option	Single rod clevis	●	●	●	●	●	●	●
	Double rod clevis (with pin)	●	●	●	●	●	●	●
	Rod boot	●	●	●	●	●	●	●

CJ1

CJP

CJ2

CM2

C85

CG1

MB

C95

CA1

CS1

Series C95

Theoretical Force

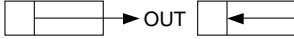
(Unit : N) 

Bore size (mm)	Rod diameter (mm)	Operating direction	Piston area (mm ²)	Operating pressure (MPa)									
				0.2	0.3	0.4	0.5	0.6	0.7	0.8	0.9	1.0	
32	12	OUT	804	161	241	322	402	482	563	643	724	804	
		IN	691	138	207	276	346	415	484	553	622	691	
40	16	OUT	1257	251	377	503	629	754	880	1006	1131	1257	
		IN	1056	211	317	422	528	634	739	845	950	1056	
50	20	OUT	1963	393	589	785	982	1178	1374	1570	1767	1963	
		IN	1649	330	495	660	825	989	1154	1319	1484	1649	
63	20	OUT	3117	623	935	1247	1559	1870	2182	2494	2805	3117	
		IN	2803	561	841	1121	1402	1682	1962	2242	2523	2803	
80	25	OUT	5027	1005	1508	2011	2514	3016	3519	4022	4524	5027	
		IN	4536	907	1361	1814	2268	2722	3175	3629	4082	4536	
100	30	OUT	7854	1571	2356	3142	3927	4712	5498	6283	7068	7854	
		IN	7147	1429	2144	2859	3574	4288	5003	5718	6432	7147	

Note) Theoretical force(N) = Pressure (MPa) X Piston area (mm²)

Weight Table/Aluminum Tube

Bore size (mm)		32	40	50	63	80	100
Basic weight	Basic	0.56	0.84	1.39	1.91	3.22	4.24
	Foot	0.16	0.20	0.38	0.46	0.89	1.09
	Flange	0.20	0.23	0.47	0.58	1.30	1.81
	Single clevis	0.16	0.23	0.37	0.60	1.07	1.73
	Double clevis	0.20	0.32	0.45	0.71	1.28	2.11
	Trunnion	0.71	1.10	1.73	2.48	4.25	5.95
Additional weight per 50 stroke	All mounting brackets	0.11	0.16	0.26	0.27	0.42	0.56
Accessories	Single rod clevis	0.15	0.23	0.26	0.26	0.60	0.83
	Double rod clevis (with pin)	0.22	0.37	0.43	0.43	0.87	1.27

Calculation example: C95SD40-100

- Basic weight 0.84 (Basic, ø40)
 - Additional weight ... 0.16/50 stroke
 - Cylinder stroke 100 stroke
 - Mounting 0.32 (Double clevis)
- 0.84+0.16 X 100/50+0.32=1.48kg

Allowable Kinetic Energy

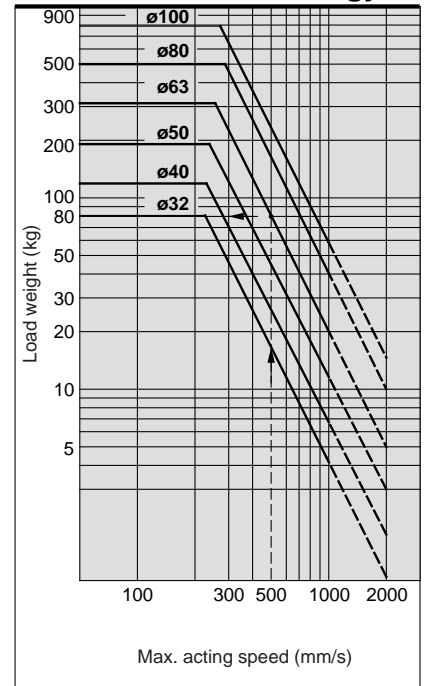

Example: Load limit at rod end when air cylinder ø63 is actuated with max. actuating speed 500mm/s. See the intersection of lateral axis 500mm/s and ø63 line, and extend the intersection to left. Thus the allowable load is 80kg.

Construction

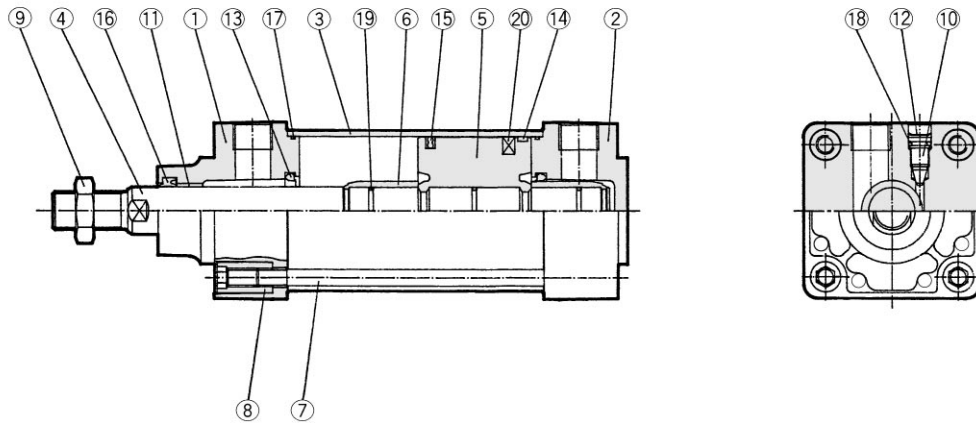

- CJ1
- CJP
- CJ2
- CM2
- C85
- CG1
- MB
- C95**
- CA1
- CS1

Component Parts

No.	Description	Material	Note
①	Rod cover	Aluminum alloy	
②	Head cover	Aluminum alloy	
③	Cylinder tube	Aluminum alloy	
④	Piston rod	C45 hard chrome	
⑤	Piston	Aluminum alloy	
⑥	Cushion ring	Roller steel	
⑦	Tie rod	Steel	(Zinc chromate plated)
⑧	Tie rod nut	Steel	(Zinc chromate plated)
⑨	Mounting nut	Steel	(Zinc chromate plated)
⑩	Cushion adjustment screw	Steel	(Zinc chromate plated)
⑪	Bushing	Lead bronze casting	
⑫	Serrated washer	Steel	(Zinc chromate plated)
⑬	Cushion seal	NBR	

No.	Description	Material	Note
⑭	Wearing	PRC compound	
⑮	Piston seal	NBR	
⑯	Rod seal/Gasket	NBR	
⑰	Cylinder tube gasket	NBR	
⑱	Cushion screw seal	NBR	
⑲	Piston gasket	NBR	
⑳	Magnet ring		

Seal Kits

Bore size (mm)	Kit No.	Contents
32	CS95-32	Kits include items 13 to 17 for ø32, 12 to 18 for ø40 to ø100 from the table above.
40	CS95-40	
50	CS95-50	
63	CS95-63	
80	CS95-80	
100	CS95-100	

* Seal kits consist of items 13 to 17 for ø32, items 12 to 18 for ø40 to ø100 contained in one kit, and can be ordered using the order number for each respective tube bore size.

Series C95

Without Mounting Bracket

C95SBø-Stroke

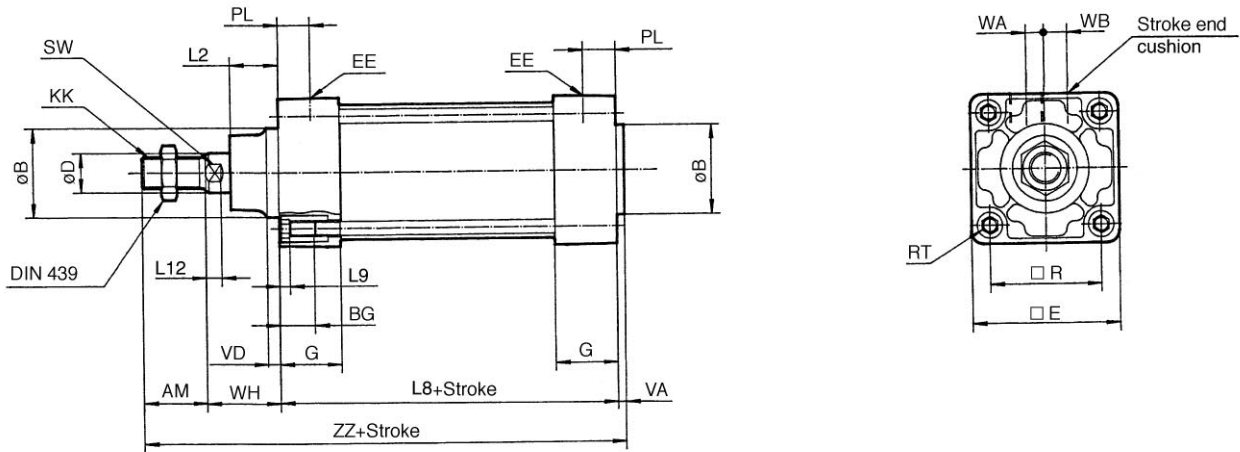

C95SBø-Stroke W

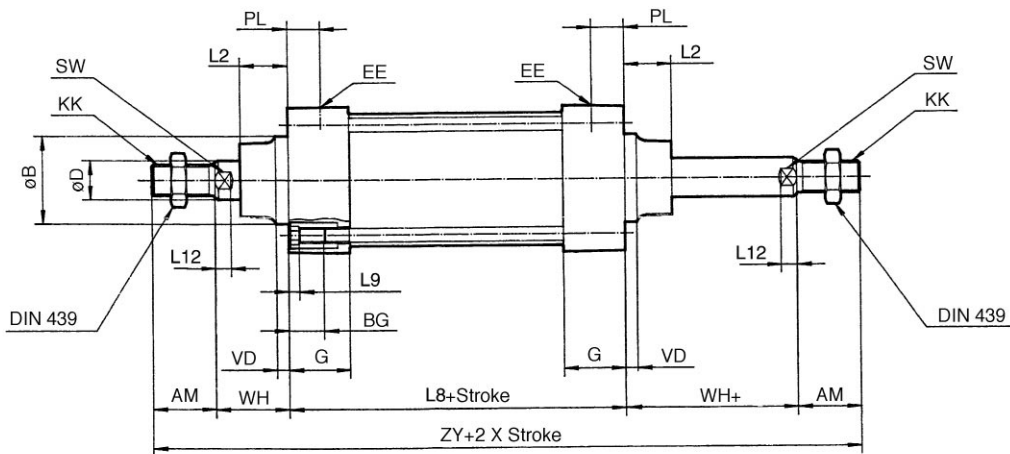

Bore (mm)	AM	øB e11	øD	EE	PL	RT	L12	KK	SW	G	BG	L8	VD	VA	WA	WB	WH	ZZ	ZY	□E	□R	L2	L9
32	22	30	12	G1/8	13	M6	6	M10 X 1.25	10	27	16	94	4	4	4	6.5	26	146	190	46	32.5	15	4
40	24	35	16	G1/4	14	M6	6.5	M12 X 1.25	13	27	16	105	4	4	4	9	30	163	213	52	38	17	4
50	32	40	20	G1/4	15.5	M8	8	M16 X 1.5	16	31.5	16	106	6	4	5	10.5	37	179	244	65	46.5	24	5
63	32	45	20	G3/8	16.5	M8	8	M16 X 1.5	16	31.5	16	121	6	4	9	12	37	194	259	75	56.5	24	5
80	40	45	25	G3/8	19	M10	10	M20 X 1.5	21	38	16	128	8	4	11.5	14	46	218	300	95	72	30	5
100	40	55	30	G1/2	19	M10	10	M20 X 1.5	21	38	16	138	8	4	17	15	51	233	320	114	89	32	5

With Mounting Bracket

Foot L

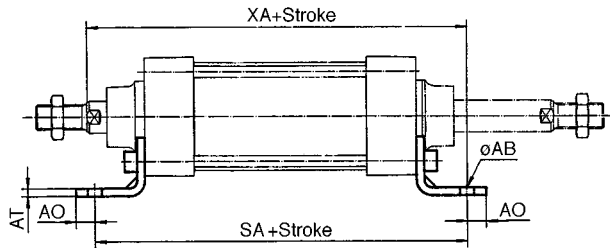
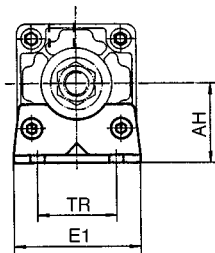

Centre trunnion T

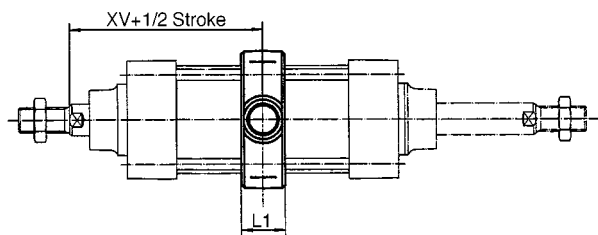
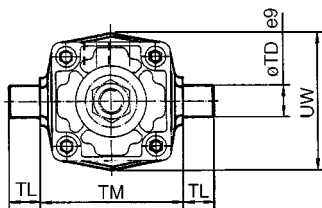

Flange F

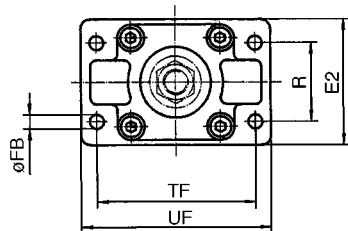

Mounting at the back

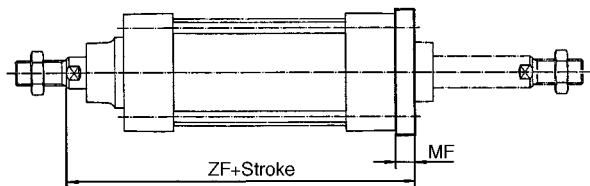

Mounting at the front

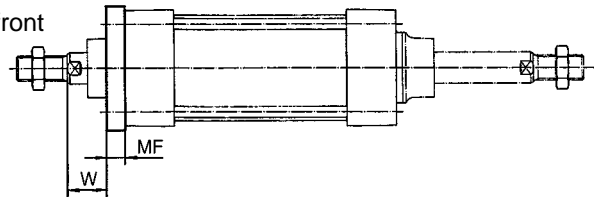

Rear single clevis C

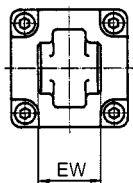

Rear double clevis D

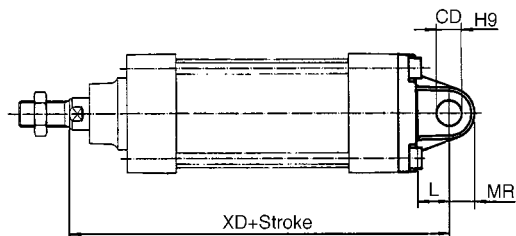
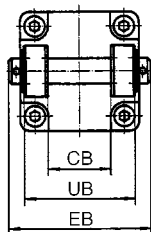

Bore (mm)	E1	R	W	MF	ZF	øFB	CD	EB	L	XD	UB	CB	EW	MR	TR	AO	AT	XA	SA	AH	øAB	L1	XV	TL	øTD	TM	UW	TF	UF	E2
32	48	32	16	10	130	7	10	65	12	142	45	26	26	9.5	32	10	4.5	144	142	32	7	17	73	12	12	50	49	64	79	50
40	55	36	20	10	145	9	12	75	15	160	52	28	28	12	36	11	4.5	163	161	36	10	22	82.5	16	16	63	58	72	90	55
50	68	45	25	12	155	9	12	80	15	170	60	32	32	12	45	12	5.5	175	170	45	10	22	90	16	16	75	71	90	110	70
63	80	50	25	12	170	9	16	90	20	190	70	40	40	16	50	12	5.5	190	185	50	10	28	97.5	20	20	90	87	100	120	80
80	100	63	30	16	190	12	16	110	20	210	90	50	50	16	63	14	6.5	215	210	63	12	34	110	20	20	110	110	126	153	100
100	120	75	35	16	205	14	20	140	25	230	110	60	60	20	75	16	6.5	230	220	71	14.5	40	120	25	25	132	136	150	178	120

- CJ1
- CJP
- CJ2
- CM2
- C85
- CG1
- MB
- C95**
- CA1
- CS1

Series C95

Accessories

Rear single clevis C

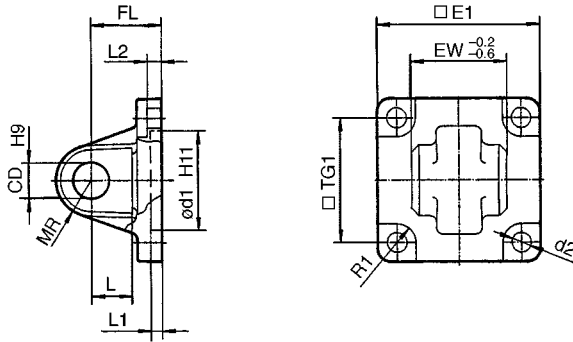

Rear double clevis D

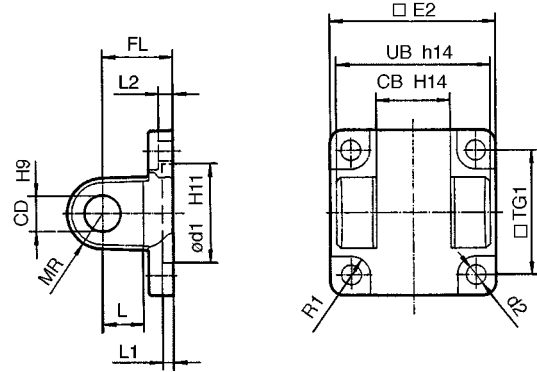

Bore (mm)	□E1	EW	□TG1	FL	L1	L	L2	ød1	CD	MR	d2	R1	□E2	UB	CB
32	45	26	32.5	22	5	12	5.5	30	10	9.5	6.6	6.5	48	45	26
40	51	28	38	25	5	15	5.5	35	12	12	6.6	6.5	56	52	28
50	64	32	46.5	27	5	15	6.5	40	12	12	9	8.5	64	60	32
63	74	40	56.5	32	5	20	6.5	45	16	16	9	8.5	75	70	40
80	94	50	72	36	5	20	10	45	16	16	11	11	95	90	50
100	113	60	89	41	5	25	10	55	20	20	11	12	115	110	60

Counter pivot E

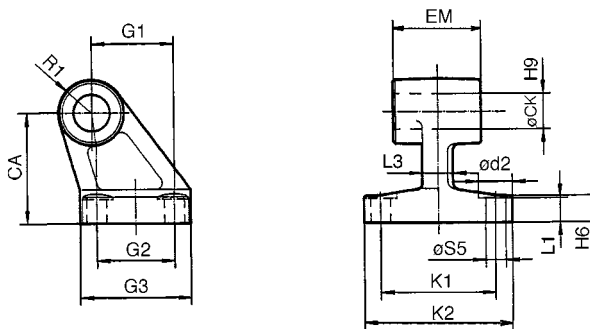

Bore (mm)	ød2	øCK	øS5	K1	K2	L3	G1	L1	G2	EM	G3	CA	H6	R1
32	11	10	6.6	38	51	10	21	7	18	26	31	32	8	10
40	11	12	6.6	41	54	10	24	9	22	28	35	36	10	11
50	15	12	9	50	65	12	33	11	30	32	45	45	12	12
63	15	16	9	52	67	14	37	11	35	40	50	50	12	15
80	18	16	11	66	86	18	47	12.5	40	50	60	63	14	15
100	18	20	11	76	96	20	55	13.5	50	60	70	71	15	19

Accessories

Floating joint JA

Steel, zinc chromate plated

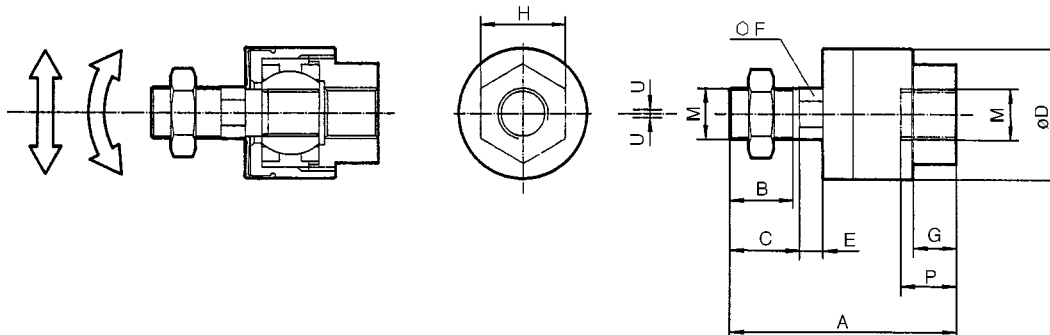

Bore (mm)	M	A	B	C	øD	E	F	G	H	P	U	Load (kn)	Weight (g)	Radial deflection
32	M10 X 1.25	49.5	19.5	—	24	5	8	8	17	9	0.5	2.5	70	±5
40	M12 X 1.25	60	20	—	31	6	11	11	22	13	0.75	4.4	160	
50/63	M16 X 1.5	71.5	22	—	41	7.5	14	13.5	27	15	1.0	11	300	
80/100	M20 X 1.5	101	28	31	59.5	11.5	24	16	32	18	2.0	18	1080	

- CJ1
- CJP
- CJ2
- CM2
- C85
- CG1
- MB
- C95**
- CA1
- CS1

Piston rod clevis GKM (DIN 71752)

Steel, zinc chromate plated

Bore (mm)	e	b	d	øf	L1	c	a
32	M10 X 1.25	10	40	10	52	20	20
40	M12 X 1.25	12	48	12	62	24	24
50/63	M16 X 1.5	16	64	16	83	32	32
80/100	M20 X 1.5	20	80	20	105	40	40

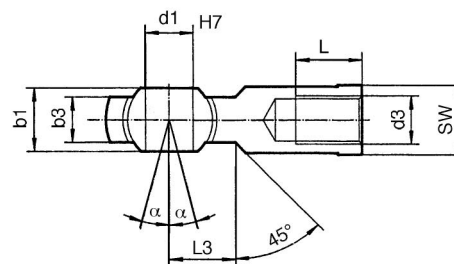
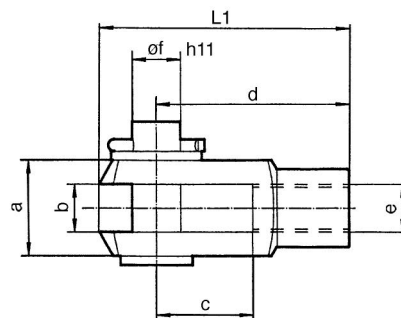

Piston rod ball joint KJ (DIN 648)

Steel, zinc chromate plated

Bore (mm)	d3	d1	h	d6	b3	b1	L	d7	α	L3	SW
32	M10 X 1.25	10	43	28	10.5	14	20	19	13°	14	17
40	M12 X 1.25	12	50	32	12	16	22	22	13°	16	19
50/63	M16 X 1.5	16	64	42	15	21	28	27	15°	26	32
80/100	M20 X 1.5	20	77	50	18	25	33	34	15°	26	32

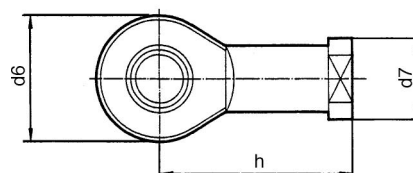

ISO Cylinder/Non-rotating Rod: Double Acting

Series C95K

ø32, ø40, ø50, ø63, ø80, ø100

How to Order

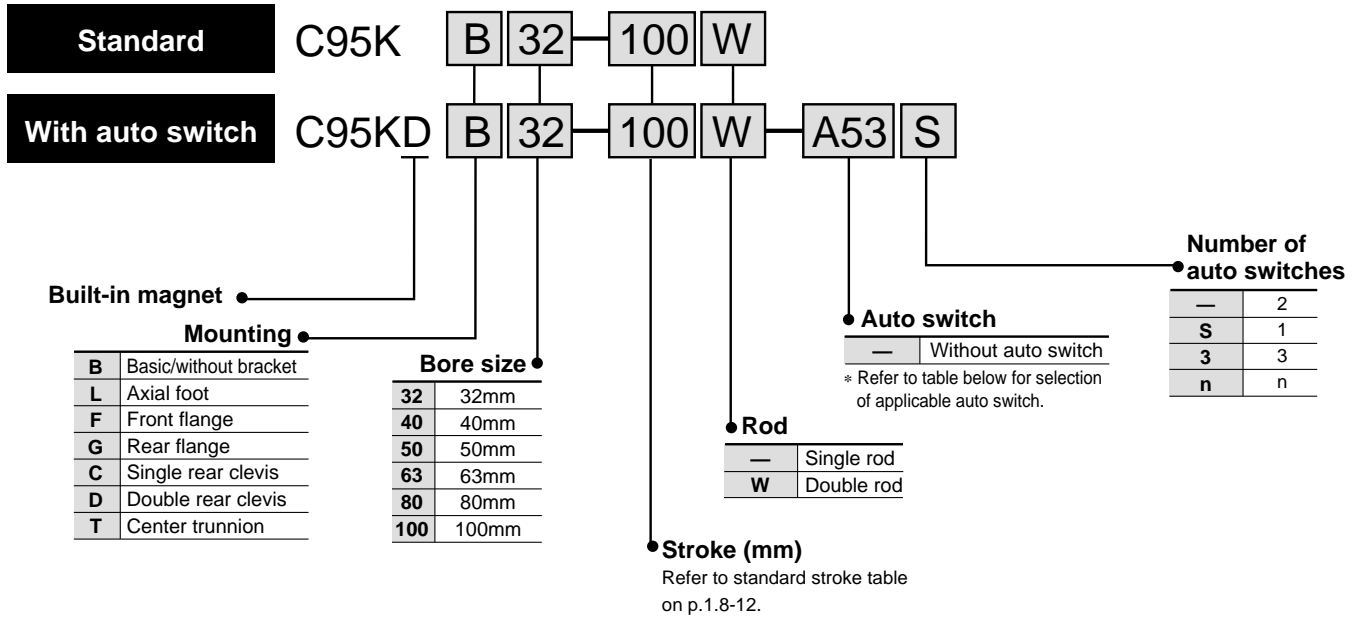

Applicable Auto Switches/Tie rod mounting

Style	Special function	Electrical entry	Indicator	Load voltage			Auto switch model	Lead wire (m)*			Applicable load			
				Wiring (Output)	DC	AC		0.5 (—)	3 (L)	5 (Z)				
Reed switch	—	Grommet	Yes	3 wire (NPN)	—	5V	—	A56	●	●	—	IC	—	
				2 wire	24V	12V	—	—	A53	●	●	●	—	Relay PLC
						5V,12V	100V,200V	—	A54	●	●	●	—	
						12V	200V or less	—	A67	●	●	—	IC	
						—	—	—	A64	●	●	—	—	
Diagnosis indication (2 color)	Yes	—	—	—	—	A59W	●	●	—	—				
Solid state switch	—	Grommet	Yes	3 wire (NPN)	24V	5V,12V	—	F59	●	●	○	IC	Relay PLC	
				3 wire (PNP)				F5P	●	●	○	—		
				2 wire	—	100V,200V	J51	●	●	○	—			
							J59	●	●	○	—			
				Diagnosis indication (2 color)	Yes	5V,12V	F59W	●	●	○	IC			
							F5PW	●	●	○	—			
							J59W	●	●	○	—			
				Water resistant (2 color)	3 wire (NPN)	24V	12V	—	F5BA	—	●	○		—
				With timer					F5NT	—	●	○		IC
				Diagnosis output (2 color)	3 wire (NPN)	5V,12V	—	F59F	●	●	○	—		
Latch diagnosis output (2 color)	4 wire (NPN)	—	F5LF	●	●			○	—					

* Lead wire length 0.5m..... — (Example: A53)
 3m..... L (Example: A53L)
 5m..... Z (Example: A53Z)

○: Manufactured upon receipt of order.

Mounting Bracket Part No.

Bore size	ø32	ø40	ø50	ø63	ø80	ø100
Foot⁽¹⁾	L5032	L5040	L5050	L5063	L5080	L5100
Flange	F5032	F5040	F5050	F5063	F5080	F5100
Single rear clevis	C5032	C5040	C5050	C5063	C5080	C5100
Double rear clevis	D5032	D5040	D5050	D5063	D5080	D5100

Note 1) Two foot brackets required for one cylinder.
 Note 2) Accessories for each mounting bracket are as follows.
 Foot, Flange, Single clevis: Mounting bolts
 Double rear clevis: Clevis pin

Auto Switch Mounting Bracket Part No.

Bore size	ø32, ø40	ø50, ø63	ø80, ø100
Mounting bracket	BT-03	BT-05	BT-06

ISO Cylinder/Non-rotating Rod: Double Acting *Series C95K*

Specifications



JIS Symbol
Double acting

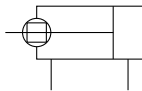

Bore size	ø32	ø40	ø50	ø63	ø80	ø100
Action	Double acting					
Fluid	Air					
Proof pressure	1.5MPa					
Max. operating pressure	1.0MPa					
Min. operating pressure	0.05MPa					
Ambient and fluid temperature	Without magnet -10 to 70°C (No freezing)					
	With magnet -10 to 60°C (No freezing)					
Lubrication	Not required (Non-lube)					
Operating piston speed	50 to 1000mm/s					
Allowable stroke tolerance	to 250: $^{+1.0}_0$, 251 to 1000: $^{+1.4}_0$, 1001 to 1500: $^{+1.8}_0$					
Cushion	Both ends (Air cushion) ⁽¹⁾					
Thread tolerance	JIS class 2					
Port size	G1/8	G1/4	G1/4	G3/8	G3/8	G1/2
Mounting	Basic, axial direction foot, front flange, rear flange, single rear clevis, double rear clevis, center trunnion					
Non-rotating accuracy	ø32, ø40		±0.5°			
	ø50, ø63		±0.5°			
	ø80, ø100		±0.3°			
Allowable rotating torque (Nm) max.	ø32	0.25	ø80		0.79	
	ø40	0.45	ø100		0.93	
	ø50, ø63	0.64	—		—	

Note 1) Absorbable kinetic energy by cushion mechanism is identical to double acting single rod.
When requesting a cylinder without air cushion, cylinder utilizes rubber bumpers which increase cylinder's overall length.

CJ1

CJP

CJ2

CM2

C85

CG1

MB

C95

CA1

CS1

Accessories

Mounting		Basic	Foot	Front flange	Rear flange	Single rear clevis	Double rear clevis	Center trunnion
Standard	Rod end nut	●	●	●	●	●	●	●
	Clevis pin	—	—	—	—	—	●	—
Option	Single rod clevis	●	●	●	●	●	●	●
	Double rod clevis (with pin)	●	●	●	●	●	●	●
	Rod boot	●	●	●	●	●	●	●

Weight/Aluminum Tube

Bore size (mm)		32	40	50	63	80	100
Basic weight	Basic	0.56	0.84	1.39	1.91	3.22	4.24
	Axial foot	0.16	0.20	0.38	0.46	0.89	1.09
	Flange	0.20	0.23	0.47	0.58	1.30	1.81
	Single clevis	0.16	0.23	0.37	0.60	1.07	1.73
	Double clevis	0.20	0.32	0.45	0.71	1.28	2.11
	Center trunnion	0.71	1.10	1.73	2.48	4.25	5.95
Additional weight per 50 stroke	All mounting brackets	0.11	0.16	0.26	0.27	0.42	0.56
Accessories	Single rod clevis	0.15	0.23	0.26	0.26	0.60	0.83
	Double rod clevis (with pin)	0.22	0.37	0.43	0.43	0.87	1.27

Calculation example: C95KD40-100

- Basic weight 0.84 (Basic)
 - Additional weight ... 0.16/50 stroke
 - Cylinder stroke 100 stroke
 - Mounting 0.32 (Double clevis)
- 0.84+0.16 X 100/50+0.32=1.48kg

Series C95K

Standard Stroke

Bore size (mm)	Standard stroke (mm)
32	25, 50, 80, 100, 125, 160, 200, 250, 320, 400, 500
40	25, 50, 80, 100, 125, 160, 200, 250, 320, 400, 500
50	25, 50, 80, 100, 125, 160, 200, 250, 320, 400, 500, 600
63	25, 50, 80, 100, 125, 160, 200, 250, 320, 400, 500, 600
80	25, 50, 80, 100, 125, 160, 200, 250, 320, 400, 500, 600
100	25, 50, 80, 100, 125, 160, 200, 250, 320, 400, 500, 600

Intermediate strokes are available.

Minimum Strokes for Auto Switch Mounting

Refer to p.1.8-14 on "Minimum Strokes for Auto Switch Mounting".

Theoretical Force

OUT side is identical to double acting single rod. Refer to table below for IN side.

Bore size (mm)	Rod diameter (mm ²)	Bore size (mm)	Rod diameter (mm ²)
32	675	63	2804
40	1082	80	4568
50	1651	100	7223

Theoretical force (N) = Pressure (MPa) X Piston area (mm²)

Construction

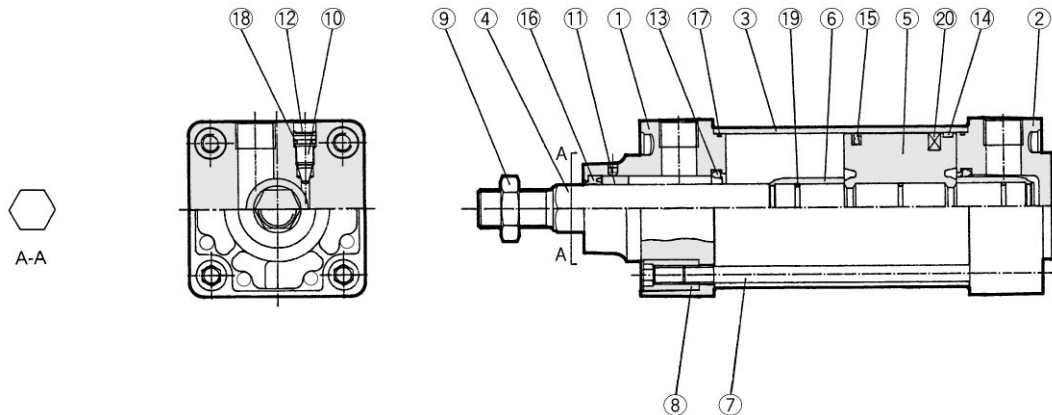

Component Parts

No.	Description	Material	Note
①	Rod cover	Aluminum alloy	
②	Head cover	Aluminum alloy	
③	Cylinder tube	Aluminum alloy	
④	Piston rod	1.4301stainless steel	
⑤	Piston	Aluminum alloy	
⑥	Cushion ring	Rolled steel	
⑦	Tie rod	Steel	(Zinc chromate plated)
⑧	Tie rod nut	Steel	(Zinc chromate plated)
⑨	Mounting nut	Steel	(Zinc chromate plated)
⑩	Cushion adjustment screw	Steel	(Zinc chromate plated)
⑪	Bushing	Lead bronze casting	
⑫	Serrated washer	Steel	(Zinc chromate plated)
⑬	Cushion seal	NBR	

No.	Description	Material	Note
⑭	Wearing	PRC compound	
⑮	Piston seal	NBR	
⑯	Rod seal/Gasket	NBR	
⑰	Cylinder tube gasket	NBR	
⑱	Cushion screw seal	NBR	
⑲	Piston gasket	NBR	
⑳	Magnet ring		

Seal Kits

Bore size (mm)	Kit No.	Contents
32	CK95-32	Kits include items 13 to 17 for ø32, 12 to 18 for ø40 to ø100 from the table above.
40	CK95-40	
50	CK95-50	
63	CK95-63	
80	CK95-80	
100	CK95-100	

* Seal kits consist of items 13 to 17 for ø32, items 12 to 18 for ø40 to ø100 contained in one kit, and can be ordered using the order number for each respective tube bore size.

ISO Cylinder/Non-rotating Rod: Double Acting **Series C95K**

Without Mounting Bracket

C95KB \emptyset -Stroke

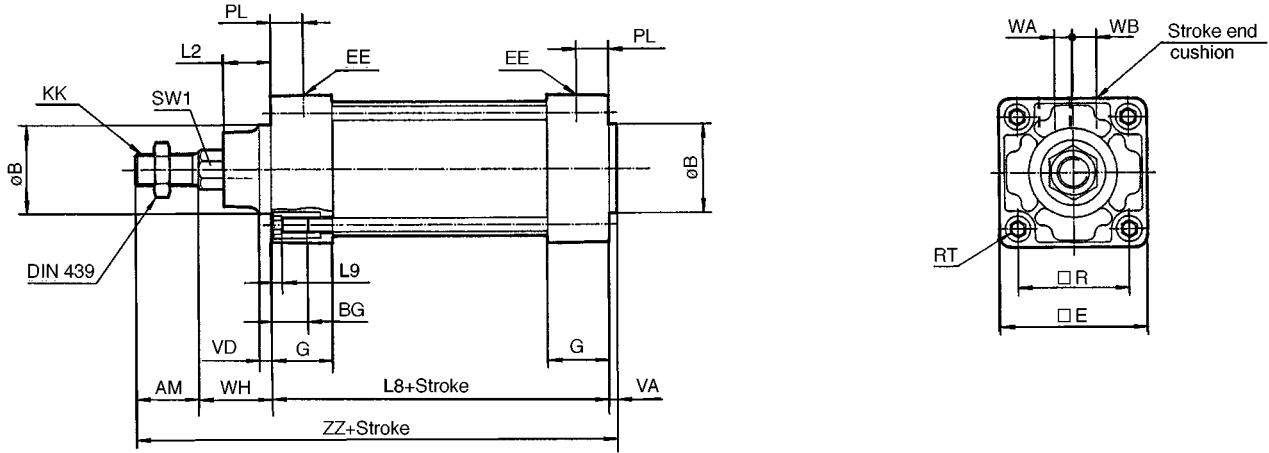

- CJ1
- CJP
- CJ2
- CM2
- C85
- CG1
- MB
- C95
- CA1
- CS1

C95KB \emptyset -Stroke W

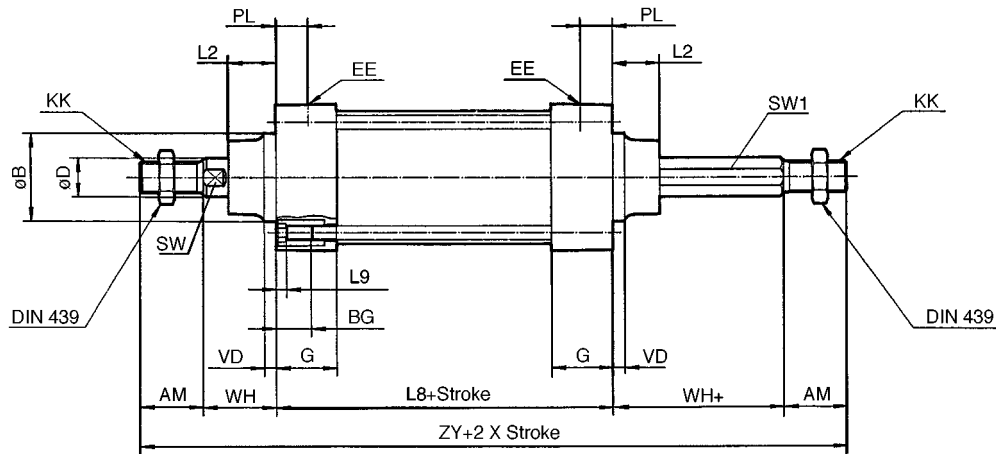

Bore size (mm)	AM	$\emptyset B_{e11}$	$\emptyset D$	EE	PL	RT	KK	SW1	SW	G	BG	L8	VD	VA	WA	WB	WH	ZZ	ZY	$\square E$	$\square R$	L2	L9
32	22	30	12	G1/8	13	M6	M10 X 1.25	12.2	10	27	16	94	4	4	4	6.5	26	146	190	46	32.5	15	4
40	24	35	16	G1/4	14	M6	M12 X 1.25	14.2	13	27	16	105	4	4	4	9	30	163	213	52	38	17	4
50	32	40	20	G1/4	15.5	M8	M16 X 1.5	19	16	31.5	16	106	6	4	5	10.5	37	179	244	65	46.5	24	5
63	32	45	20	G3/8	16.5	M8	M16 X 1.5	19	16	31.5	16	121	6	4	9	12	37	194	259	75	56.5	24	5
80	40	45	25	G3/8	19	M10	M20 X 1.5	23	21	38	16	128	8	4	11.5	14	46	218	300	95	72	30	5
100	40	55	30	G1/2	19	M10	M20 X 1.5	27	21	38	16	138	8	4	17	15	51	233	320	114	89	32	5

* Refer to p.1.8-7 through 1.8-9 for dimensions with mounting bracket and accessories.

Series C95

Auto Switch Specifications



Refer to P.5.3-17, 27, 37, 46, 54, 58 and 61 for details on auto switches.

Applicable Auto Switch



Style	Auto switch model	Electrical entry (function)
Reed switch	D-A5□/A6□	Grommet
	D-A59W	Grommet (2 color indication)
Solid state switch	D-F5□/J5□	Grommet
	D-F5□W/J59W	Grommet (2 color indication)
	D-F5BAL	Grommet (2 color indication, Water resistant)
	D-F5□F	Grommet (2 color indication, diagnostic output)
	D-F5NTL	Grommet (Timer)



Minimum Strokes for Auto Switch Mounting

Style	Auto switch model	No. of auto switches	Support bracket except center trunnion					Center trunnion						
			ø32	ø40	ø50	ø63	ø80	ø100	ø32	ø40	ø50	ø63	ø80	ø100
Reed switch	D-A5, D-A6	2 (On different faces or same face)	15					20	60	80	105	110	115	
		1	20					25	60	70	85	110	115	120
Reed switch	D-A59W	2 (On different faces or same face)	15					25	60	70	85	110	115	120
		1	10					25	60	70	85	110	115	120
Solid state switch	D-F5/J5	2 (On different faces or same face)	15					25	60	70	85	110	115	120
		1	10					25	60	70	85	110	115	120
	D-F5NTL	2 (On different faces or same face)	15					25	70	75	95	120	125	130
Solid state switch	D-F5□W D-J59W D-F5BAL D-F5□F D-F5LF	2 (On different faces or same face)	15					25	70	75	90	120	125	130
		1	10					25	70	75	90	120	125	130

Auto Switch Mounting Position and Mounting Height

Reed switch

Solid state switch

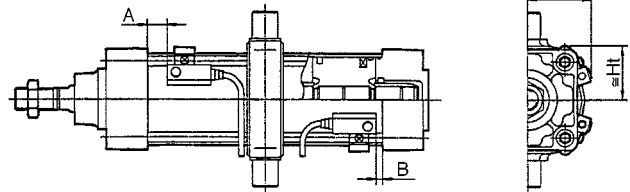
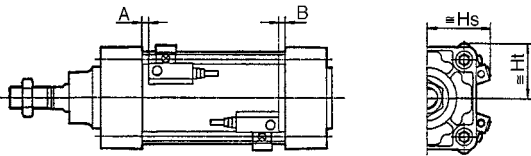

Auto Switch Mounting Position

Bore size (mm)	D-A5/D-A6		D-A59W		D-F5□ D-J5□		D-F5□W D-J59W D-F5BAL		D-F5NTL	
	A	B	A	B	A	B	A	B	A	B
ø32	10.5	0	14.5	2	17	4.5	21	8.5	22	9.5
ø40	21.5	0	25.5	2	28	4.5	32	8.5	33	9.5
ø50	23	0	27	2.5	29.5	5	33.5	9	34.5	10
ø63	28	0	32	2.5	34.5	5	38.5	9	39.5	10
ø80	28	2.5	22	6.5	24.5	9	28.5	13	29.5	14
ø100	28	2.5	32	6.5	34.5	9	38.5	13	39.5	14

Auto Switch Mounting Height

Bore size (mm)	D-A5 D-A6 D-A59W		D-F5, D-J5□ D-F5□W, D-J59W D-F5BAL, D-F5NTL	
	Ht	Hs	Ht	Hs
ø32	24.5	35	25	32.5
ø40	27.5	38.5	27.5	36.5
ø50	34.5	43.5	34	41
ø63	39.5	48.5	39	46
ø80	46.5	55	46.5	52.5
ø100	55	62	55	59.5



Series C95

Specific Product Precautions

Be sure to read before handling. Refer to p.0-39 through 0-46 for Safety Instructions, actuator precautions and auto switch precautions.

Adjustment

⚠ Warning

- ① **Do not open the cushion valve above the stopper.**
Cushion valves are provided with a crimp (ø32) or a retaining ring (ø40 to ø100) as a stopping mechanism, and the cushion valve should not be opened above that point.
If air is supplied and operation started without confirming the above condition, the cushion valve may be ejected from the cover.

Bore size (mm)	Cushion valve	Width across flats	Socket wrench
32, 40, 50	MB-32-10-C1247	2.5	JIS 4648 Hex spanner wrench 2.5
63, 80, 100	MB-63-10-C1250	4	JIS 4648 Hex spanner wrench 4

- ② **Be certain to activate the air cushion at the stroke end.**
When it is intended to use the cushion valve in the fully opened position, select a style with a damper. If this is not done, the tie-rods or piston rod assembly will be damaged.
- ③ **When replacing brackets, use the hexagon wrenches shown below.**

Bore size (mm)		Bolt	Width across flats	Tightening torque (Nm)
32, 40		MB-32-48-C1247	4	4.9
50, 63		MB-50-48-C1249	5	11
80, 100	Foot	MB-80-48AC1251	6	25
	Others	MB-80-48BC1251		

With Non-rotating Rod (Double Acting: Single Rod)

Operating Precautions

⚠ Caution

- ① **Do not apply more than the allowable rotating torque to the piston rod.**
If more than the allowable rotating torque is applied, the non-rotating guide will be deformed and there will be a significant loss of rotational accuracy. This may cause damage to the machinery.

Mounting & Piping

⚠ Caution

- ① **Mounting of a work piece at the rod end.**
When screwing a fitting or nut, etc. onto the threads at the end of the piston rod, push the piston rod into its fully retracted position, and grasp the protruding section with a wrench.
Furthermore, when tightening, take care that the torque is not applied to the non-rotating guide.

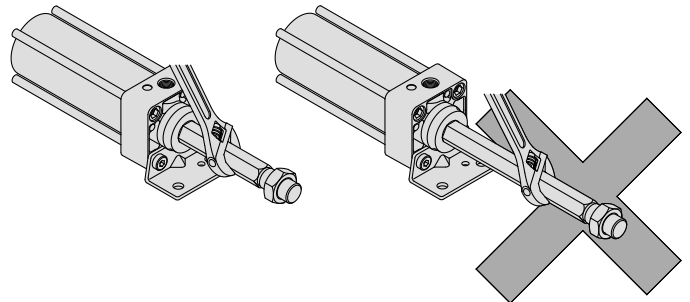

CJ1

CJP

CJ2

CM2

C85

CG1

MB

C95

CA1

CS1

CP95 serien som ses herunder, har de samme specifikationer som C95 serien. CP95 serien er blot udført med krop i profil, hvor stagboltene er skjulte.

ISO/VDMA cylinder med profilrørsudførelse

Serie CP95

- Ø32•40•50•63•80•100
- ISO- og VDMA-standard 24562
- Konstruktion med tildækkede trækankre
- Indstillelig endeslagsdæmpning
- Pladsbesparende og fleksibel montering af reed-kontakt



Udførelse	Model	Stempel-hastighed	Stempel Ø [mm]	Standardslag-længde [mm]	Udførelse
Standard	CP95	50-1000mm/s	32, 40, 50 63, 80, 100	25 - 800 Maks. slag- længde 1000mm	Med reed-kontakt
Med gennemgængelig stempelstang	CP95W				Div. stempel- stangsudførelser
Med drejesikret stempelstang	CP95K				Langsom vanding

Befæstigelse

C95, C95W — Fod, flange, kontraleje, svingleje i midten, drejetap



Reed-kontakter:

D-Z73L
D-Z80L
D-F7PL
D-759BL
D-Y69BL