

Swash-plate Axial Piston Pump K3VL

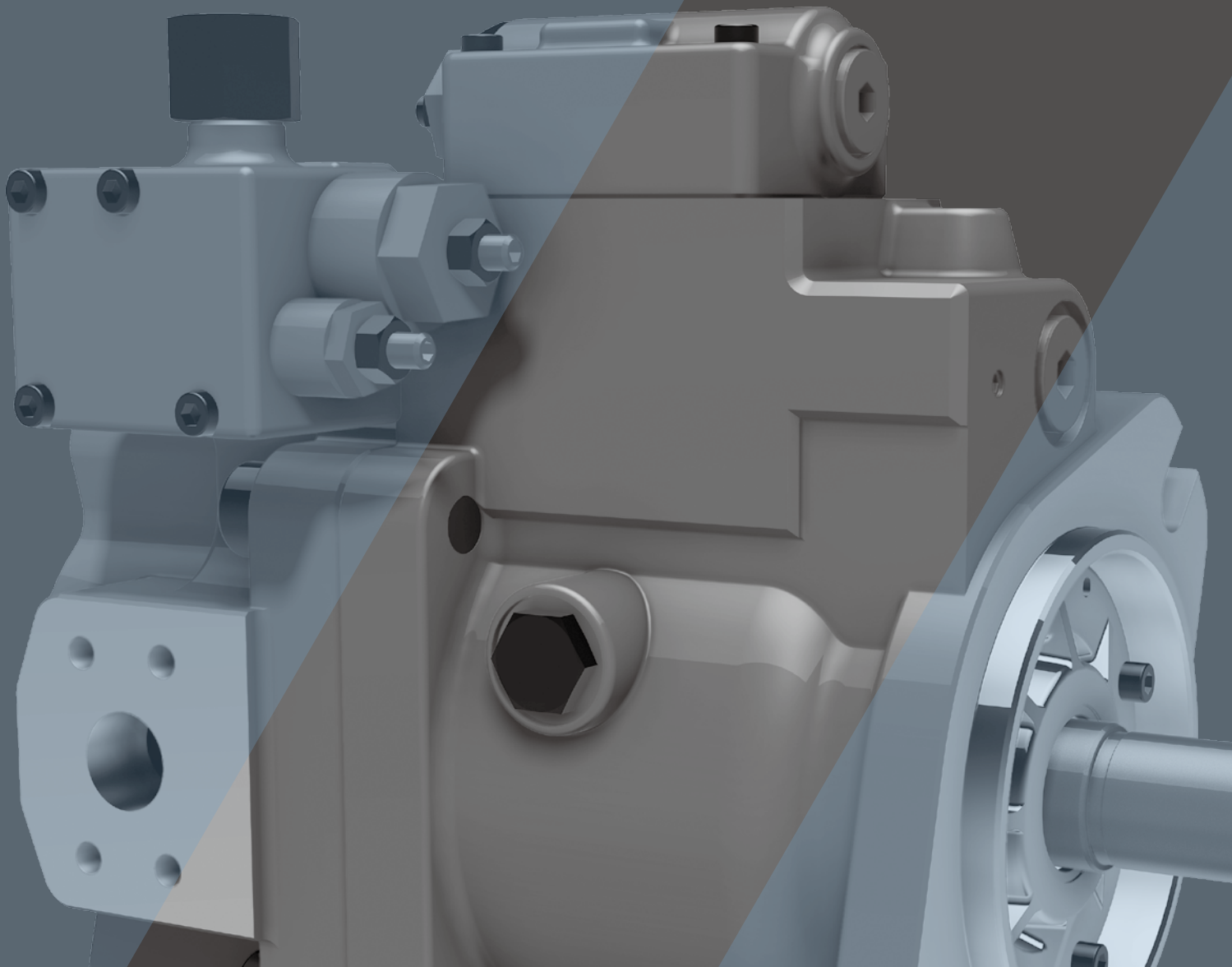

CONTENTS

Specifications and Features	2
1. Ordering Code	
1-1. Pump Options	3
1-2. Regulator Options	4
2. Technical Information	
2-1. Technical Data	5 - 7
2-2. Specifications	8 - 10
2-3. Performance Data	11 - 17
2-5. Radial Loading Capacity	18
2-6. Functional Description of Regulator	19 - 23
2-7. Torque Limiter Settings	24 - 25
2-8. Installation	26 - 30
3. Dimensions	
3-1. K3VL28 Installation	31 - 33
3-2. K3VL45/60 Installation	34 - 38
3-3. K3VL80 Installation	39 - 43
3-4. K3VL112/140 Installation	44 - 50
3-5. K3VL200 Installation	51 - 55
3-6. K3VL200H Installation	56 - 60
3-7. Electric Displacement Control	61 - 62

K3VL B Series

Swash-plate Axial Piston Pump

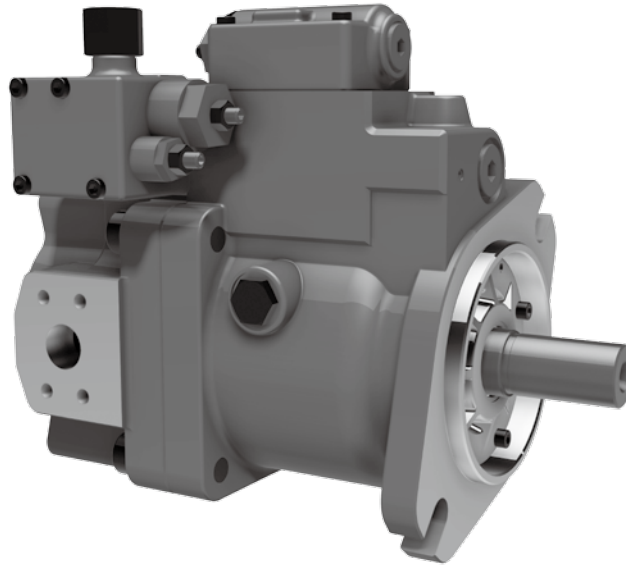

■ General Descriptions

The K3VL Series Swash Plate Type Axial Piston Pumps are designed to satisfy the marine, mobile and industrial markets industrial machinery market where a medium/high pressure variable displacement pump is required.

K3VL Pumps are available in nominal displacements ranging from 28 to 200 cm³/rev with various pressure, torque limiter, and a combination of load sensing control options.

Motor Type	Capacity (cm ³ /rev)	Rated Pressure (bar)	Maximum Self Priming Speed (rpm)
K3VL28	28	320	3000
K3VL45	45	320	2700
K3VL60	60	280	2400
K3VL80	80	320	2400
K3VL112	112	320	2200
K3VL140	140	320	2100
K3VL200	200	320	1900
K3VL200H	200	320	2200

■ Features

320 Bar Continuous Pressure Rating (250 bar for K3VL60)

High Overall Efficiency (>90% peak)

Exceptional Self Priming capability

SAE and ISO Mounting and Shaft

Excellent Reliability and very long Service Life

High Power to Weight Ratio

Numerous Control options

Highly Responsive Controls

Low Pulsation and Noise Emissions

Integral Unloading or Proportional Pressure Relief Valves available

High Speed Version with Integral Impeller (K3VL200H)

1

Ordering Code

1-1 Pump Options

K3VL 80 () /B - 1 0 R S S - L0 () /1-H1

K3VL Series Pump

Maximum Displacement

28	28 cm ³ /rev
45	45 cm ³ /rev
60	60 cm ³ /rev
80	80 cm ³ /rev
112	112 cm ³ /rev
140	140 cm ³ /rev
200	200 cm ³ /rev

Impeller (K3VL200 only)

H	With Impeller
---	---------------

Design Series

B	K3VL45 - 200
C	K3VL28 Only

Hydraulic Fluid Type

-	Mineral Oil (Nitrile Seals + Viton Shaft Seal)
V	Viton Seals Throughout
M	Water Glycol (Nitrile Seals including Shaft Seal)

All other fluids contact KPM UK

Circuit Type

1	Open Circuit
---	--------------

Porting Threads

M	Metric threaded
S	UNC threaded

Mounting Flange & Shaft

K	SAE Key & Mount
M	ISO Key & Mount (not K3VL200)
S	SAE Spline & Mount
R*	SAE-C Spline & D Mount (K3VL112/140 Only)
C*	SAE-C Spline & C2 Mount (K3VL112/140 Only)
X*	SAE-C Key & C2 Mount (K3VL112/140 Only)
Y*	SAE-CC Key & C2 Mount (K3VL112/140 Only)
W*	SAE-CC Spline & C2 Mount (K3VL112/140 Only)
F*	SAE-F Spline & E Mount (K3VL200 Only)

Direction of Rotation

R	Clockwise Rotation
L	Counter Clockwise Rotation

Through Drive & Porting

O	Without Through Drive
A	SAE-A Through Drive, Side Ported
B	SAE-B Through Drive, Side Ported
BB	SAE-BB Through Drive, Side Ported
C	SAE-C, 2 Bolt, Through Drive, Side Ported
C4	SAE-C, 4 Bolt, Through Drive, Side Ported
CC	SAE-CC, 2 Bolt, Through Drive, Side Ported
CC4	SAE-CC, 4 Bolt, Through Drive, Side Ported
D	SAE-D Through Drive, Side Ported
E	SAE-E Through Drive, Side Ported
R	Single Pump, Rear Ported
N	Single Pump with Steel Cover, Side Ported

* Non standard options

1-2 Regulator Options

K3VL 80 () /B - 1 0 R S S - L0 () /1-H1

Regulator Type

L0	Load Sense & Pressure Cut-Off (With R4 Bleed)
L1	Load Sense & Pressure Cut-Off (With R4 Blocked)
LM	Load Sense & Integral Unload (Normally Open)
LN	Load Sense & Integral Unload (Normally Closed)
LV	Load Sense & Integral Proportional Relief
P0	Pressure Cut-Off
PM	Pressure Cut-Off & Integral Unload (Normally Open)
PN	Pressure Cut-Off & Integral Unload (Normally Closed)
PV	Pressure Cut-Off & Integral Proportional Relief

Additional Control Options

Blank	Without Additional Controls
Either Torque Limit Control	
/1-S##	Special Low Setting Range*
/1-L##	Low Setting Range
/1-M##	Medium Setting Range
/1-H##	High Setting Range
or Displacement Control	
/1-E0	Electric Displacement Control (Pilot Pressure Required)
/1-Q0	Pilot Operated Displacement Control

Unloader Solenoid

Blank	For all other options except PN/PM/LN/LM
115A	115 V AC, 50, 60 Hz - DIN 43550 Plug
230A	230 V AC, 50, 60 Hz - DIN 43550 Plug
12D	12 V DC - DIN 43550 Plug
24D	24 V DC - DIN 43550 Plug

- see Torque Setting Table below
 * Non Standard Options - Contact KPM UK

Torque Limiter Control - Setting Table

		Prime Mover Input Torque (Nm)																																
		30	36	41	46	49	53	61	73	82	91	100	107	121	146	154	163	182	200	216	246	298	307	367	409	450	492	540	610	618	711	752		
K3VL Frame Size	45	S4	S3	S2	S1	L4	L3	L2	L1	M4	M3	M2	M1	H4	H3	H2	H1	-	-	-	-	-	-	-	-	-	-	-	-	-	-	-		
	60	-	-	-	S4	S3	S2	S1	L4	L3	L2	L1	M4	M3	M2	H3	H2	H1	-	-	-	-	-	-	-	-	-	-	-	-	-	-		
	80	-	-	-	S4	S3	S2	S1	L6	L5	L4	L3	L2	L1	M4	M3	M2	M1	H4	H3	H2	H1	-	-	-	-	-	-	-	-	-	-	-	
	112	-	-	-	-	-	-	S6	S5	S4	S3	S2	S1	L4	L3	L2	L1	M4	M3	M2	M1	H4	H3	H2	H1	-	-	-	-	-	-	-	-	
	140	-	-	-	-	-	-	-	-	-	S4	S3	S2	S1	L6	L5	L4	L3	L2	L1	M3	M2	M1	H4	H3	H2	H1	-	-	-	-	-	-	-
	200	-	-	-	-	-	-	-	-	-	-	-	-	-	-	-	-	S2	S1	L5	L4	L3	L2	L1	M3	M2	M1	H6	H5	H4	H3	H2	H1	

2 Technical Information

2-1 Technical Data

For applications outside the following parameters, please consult KPM UK.

◆ Hydraulic Data

Pressure Fluid Mineral oil, polyol ester and water glycol.

Use a high quality, anti-wear, mineral based hydraulic fluid when the pressure exceeds 206 bar. In applications where fire resistant fluids are required consult KPM UK.

◆ Fluid selection

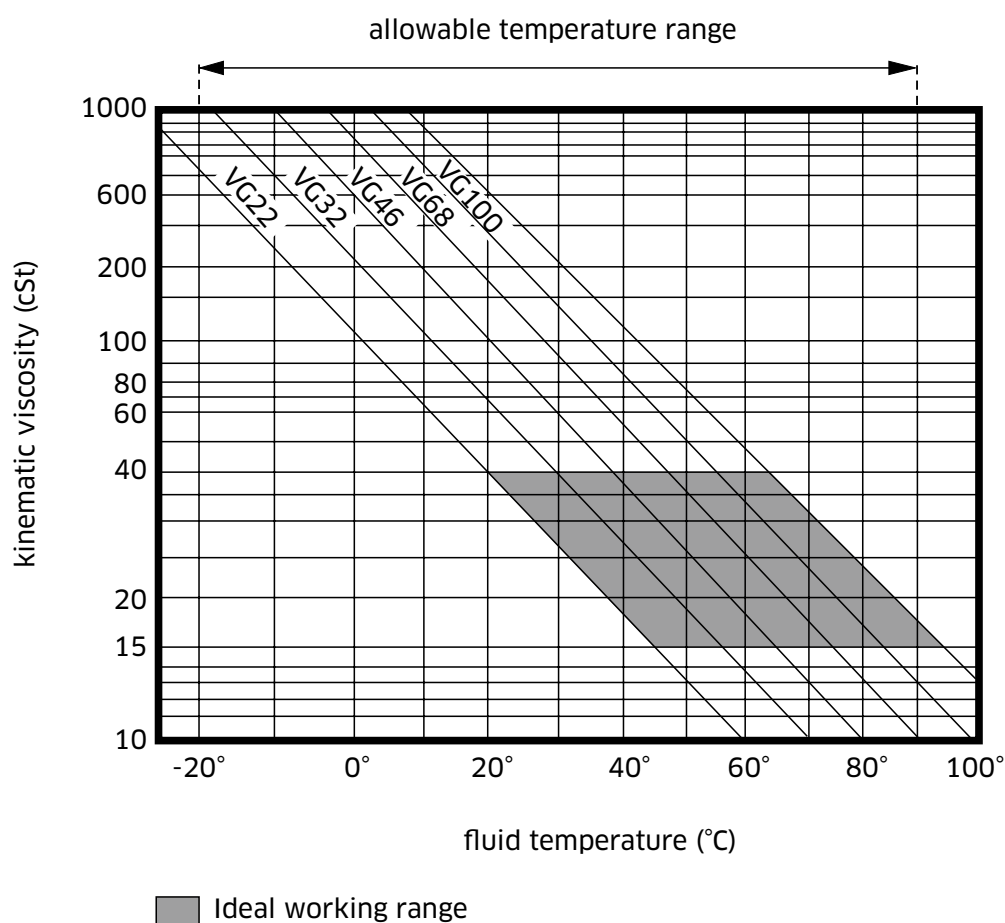

2-1 Technical Data (cont)

◆ Filtration & Contamination Control

Filtration

The most important means to prevent premature damage to the pump and associated equipment and to extend its working life, is to ensure that hydraulic fluid contamination control of the system is working effectively.

This begins by ensuring that at the time of installation that all piping, tanks etc. are rigorously cleaned in a sanitary way. Flushing should be provided using an off line filtration system and after flushing the filter elements should be replaced.

A full flow return line filter of 10 micron nominal should be utilised to prevent contaminant ingress from the external environment, a 5 to 10 micron filter within the tank's breather is also recommended.

◆ Suggested Acceptable Contamination Level

The relationship between contamination level and pump life is very difficult to predict as it depends on the type and nature of the contaminant present in the system. Sand or Silica in particular, due to its abrasive nature, does significantly reduce the expected life of a pump. Based on the precondition that there is no significant presence of Silica type substances then a minimum Cleanliness level of -/18/15 ISO 4406 or SAE AS 4059E Table 1 Class 9 (NAS 1638 Class 9).

◆ Working Fluid Types

Anti-Wear Type Hydraulic fluid

It is generally recommended to use an anti-wear hydraulic fluid like mineral oil when the operating pressure exceeds 206 bar.

Fire-resistant Fluids

Some kind of fire-resistant fluids require special materials for seals, paint and metal finishing. Please consult KPM UK and provide details of the particular fluid specification and the working conditions so that any special requirements can be ascertained.

In general, fire-resistant fluids have a low viscosity index and their viscosity also changes significantly with operating temperature and service life. For this reason, the circuit should be provided with an adequately sized cooler or forced cooling so that temperatures can be stabilised. Due to the inherent water content of some of these fluids the minimum allowable suction pressure will be higher than that of an equivalent mineral oil and so needs to be fully evaluated by KPM UK. The following table provides an overview of the precautions and characteristics that can be expected with these types of fluids.

Fluid Type Parameter	Mineral Oil	Polyol Ester	Water Glycol
Maximum Pressure (bar)	320	320	210
Recommended Temperature Range (deg C)	20 ~ 60	20 ~ 60	20 ~ 60
Cavitation susceptibility	○	△	△
Expected life expectancy compared to mineral oil	100%	<100%	20%

○ recommended △ usable (higher density)

2-1 Technical Data (cont)

◆ Pump Start Up Precautions

Pump Case Filling

Be sure to fill the pump casing with oil through the drain port, filling only the suction line with oil is totally insufficient. The pump contains bearings and high-speed sliding parts including pistons with shoes and spherical bushes that need to be continuously lubricated. Part seizure or total premature failure will occur very quickly if this procedure is not rigidly followed.

Piping & Circuit Checking

Check to see that the piping and full hydraulic circuit is completed and that any gate valves etc. are open.

Direction of Rotation

Check to ensure that direction of rotation is correct and that the inlet and delivery lines are connected correctly.

Start Up

Jog start the motor and check once more for correct rotation. Run the pump unloaded for a period to ensure that all residual air within the system is released. Check for external leakage, abnormal noise and vibrations.

Case Drain Pressure

Please ensure, that the maximum steady state drain line pressure at the pump casing does not exceed 1 bar. (Maximum peak pressure 4 bar). A suitable drain line hose must be selected and return directly back to the tank and terminate below the oil level.

Long Term Out of Usage

It is undesirable to leave the pump out of use for a long period e.g. a year or more. In such a situation it is recommended that the pump is run for a short period on a more frequent basis even if it is just unloaded. With regard to a pump held in storage then rotating the shaft on a frequent basis is sufficient. If the pump is left out for more than the suggested time it will require a service inspection.

2-2 Specifications

Pump Model		K3VL28	K3VL45	K3VL60	K3VL80	K3VL112	K3VL140	K3VL200	K3VL200H
Capacity	cc/rev	28	45	60	80	112	140	200	200
Pressure ratings	Rated	320		250	320				
	Peak ^{*1}	350		280	350				
Speed ratings	Self prime ^{*2}	3,000	2,700	2,400	2,400	2,200	2,100	1,900	2,200
	Max. boosted ^{*3}	3,600	3,250	3,000	3,000	2,700	2,500	2,200	2,200
Minimum operating speed	rpm	600							
Case drain pressure	Max. continuous	1							
	Peak	4							
Weight	kg	20	25	25	35	65	65	100	122
Case fill capacity	L	0.6	0.6	0.6	0.8	1.4	1.4	3	3.2
Temperature range	°C	-40° to 95°							
Viscosity range	cSt	10 to 1,000 - viscosities greater than 200 will require a no load warm up							
Maximum contamination level		ISO/DIS 4406 20/18/15							
Standard SAE mounting flange and shaft	Mounting	2 - bolt SAE B			2 - bolt SAE C	4 - bolt SAE D		4 - bolt SAE E	
	Shaft	SAE B spline or key	SAE B-B spline or key		SAE C spline or key	SAE D spline or key		SAE D spline or key	
Optional SAE mounting flange and shaft	Mounting	-				2 - bolt SAE C		-	
	Shaft	-	SAE B spline	SAE B spline	-	SAE C or C-C spline or key		SAE F spline	
Standard ISO mounting flange and shaft	Mounting	-	2 bolt ISO 100	2 bolt ISO 100	2 bolt ISO 100	4 bolt ISO 180		-	
	Shaft	-	ISO 25 mm key	ISO 25 mm key	ISO 25 mm key	ISO 45 mm key		-	
Input shaft torque rating		refer to table 2.1							
Through drive torque rating (Nm)	SAE A	61	123						
	SAE B	155	290		340				
	SAE B-B	-	290		550				
	SAE C	-			400	700		990	
	SAE C-C	-				700		990	
	SAE D	-				700		990	
	SAE E ^{*4}	-							

*1 : The instant allowable surge pressure as defined by DIN24312. Life and durability of the pump will be affected.

*2 : Steady state inlet pressure should be greater or equal to 0 bar gauge.

*3 : Steady state inlet pressure should be greater or equal to 0.3 bar gauge. The maximum boost pressure should not exceed 10 bar.

*4 : SAE E through drive uses the SAE D shaft.

2-2 Specifications (cont)

◆ Input Shaft Torque Ratings

SAE Splined Shafts						
Shaft Designation	SAE B	SAE B-B	SAE C	SAE C-C	SAE D/E	SAE F
Input Torque Rating (Nm)	171	272	552	925	1470	1,950

SAE Keyed Shafts					
Shaft Designation	SAE B	SAE B-B	SAE C	SAE C-C	SAE D/E
Input Torque Rating (Nm)	145	230	430	700	1,250

ISO Keyed Shafts			
Shaft Designation	ISO 25 mm	ISO 32 mm	ISO 45 mm
Input Torque Rating (Nm)	145	230	430

Note:

The shaft surface will have a finite life due to wear unless adequate lubrication is provided.

2-2 Specifications (cont)

#1 Maximum allowable shaft torques are based on achieving an infinite life for a coupling assembly that is lubricated and completely clamped and utilises the full spline/key length as engagement.

The following points therefore need to be fully considered:-

- i) Lubrication of shaft couplings should be in accordance with the coupling manufacturers instructions.
- ii) The maximum allowable input shaft torque is based on ensuring an infinite life condition by limiting the resultant combined shaft bending and torsional stress.
- iii) This allowable input shaft torque can be further increased dependant on the resultant surface stress at the spline interface which is highly dependant on coupling selection and the provision of adequate spline lubrication.

If you have an application that requires higher input torque please consult KPM UK.

#2 Allowable through drive torques are based on the achieving an infinite life for a fully lubricated coupling and full spline engagement with a mineral oil based anti-wear hydraulic fluid.

Notes:

Rated Pressure

Pressure at which life and durability will not be affected.

Peak Pressure

The instant allowable surge pressure as defined by BS ISO 2944:2000. Life and durability however will be shortened.

Maximum Self Priming Speed

Values are valid for an absolute suction pressure of 1 bar. If the flow is reduced and the inlet pressure is increased the speed may also be increased.

Maximum Boosted Speed

Values stated are the absolute maximum permitted speed for which an increased inlet pressure will be required.

Weight

Approximate dry weights, dependant on exact pump type.

Hydraulic Fluid

Mineral anti wear hydraulic fluid - for other fluid types please consult KPM UK.

Viscosity Range

If viscosity is in range 200 to 1,000 cSt, then warming up is necessary before commencing full scale running.

2-3 Performance Data

K3VL28

◆ Pump Efficiency (%)

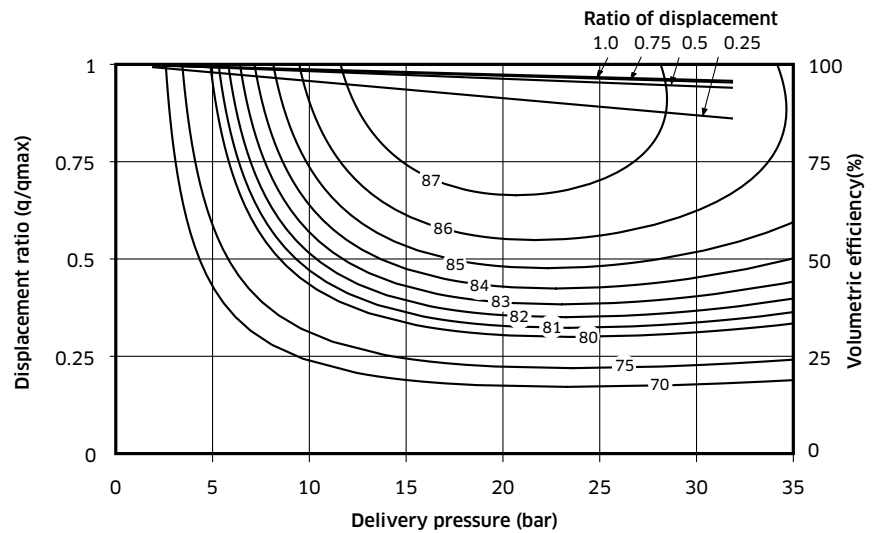

◆ Self Priming Capability

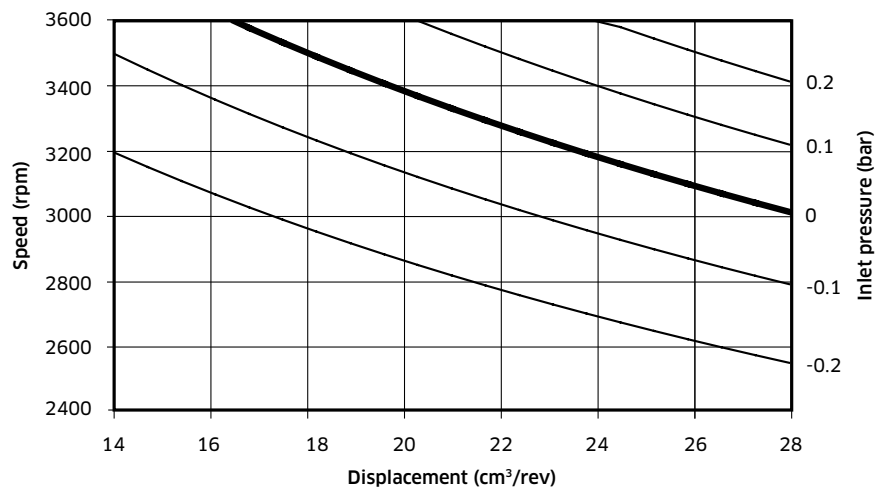

Performance Note:

All performance curves are based on the following conditions:

- 1,500 rpm
- ISO VG46 mineral oil
- 50°C oil temperature
- Atmospheric inlet condition (0 bar)

2-3 Performance Data (cont)

K3VL45

◆ Pump Efficiency (%)

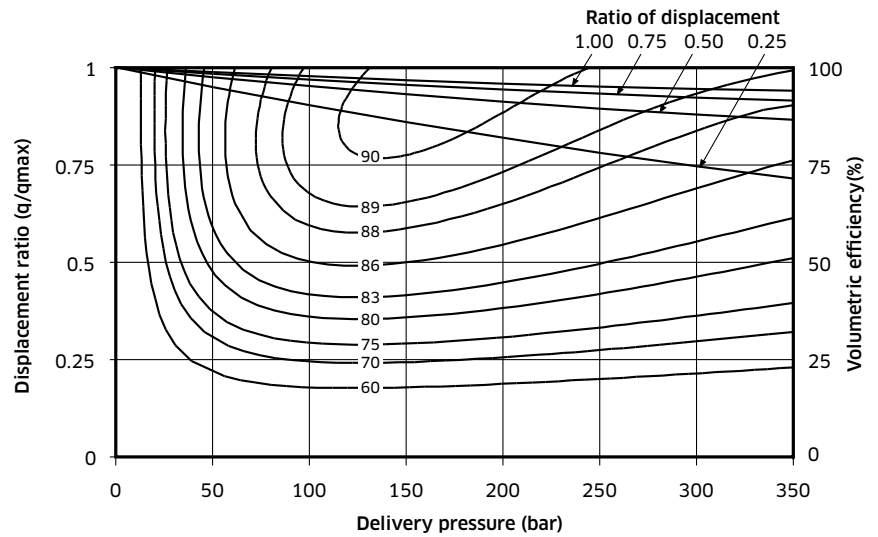

◆ Self Priming Capability

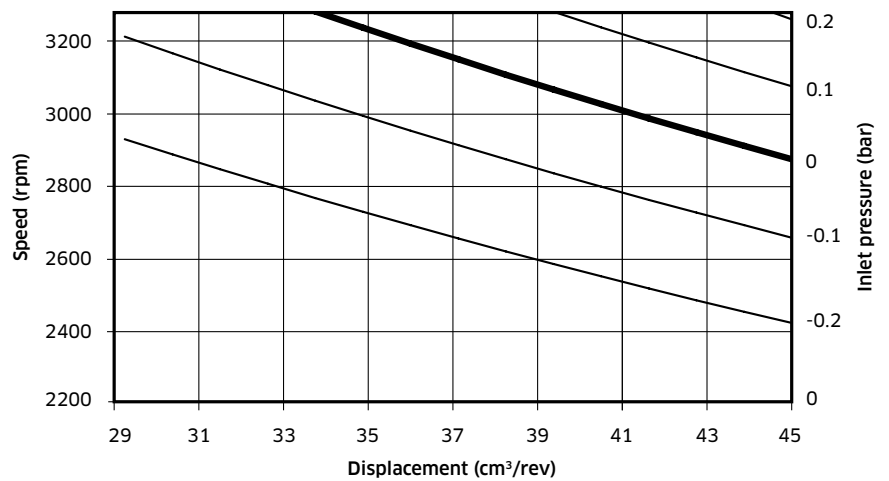

Performance Note:

All performance curves are based on the following conditions:

- 1,500 rpm
- ISO VG46 mineral oil
- 50°C oil temperature
- Atmospheric inlet condition (0 bar)

2-3 Performance Data (cont)

K3VL60

◆ Pump Efficiency (%)

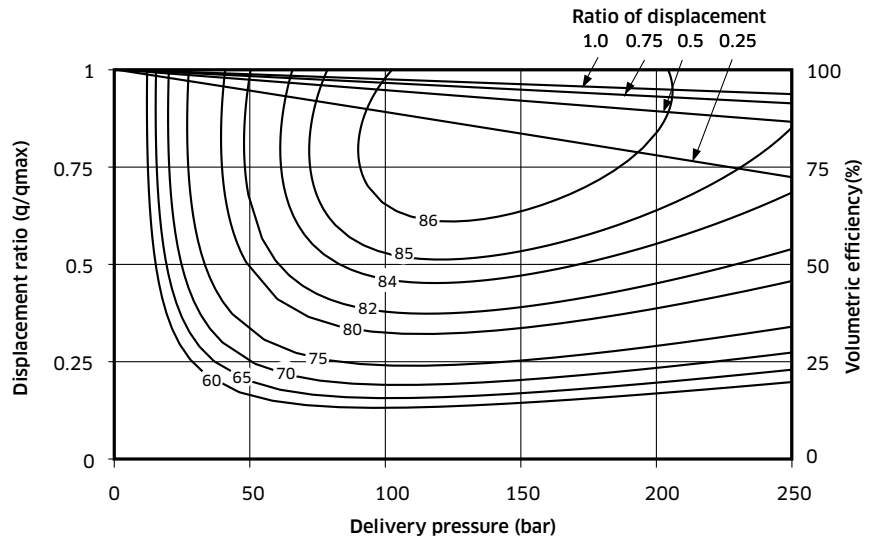

◆ Self Priming Capability

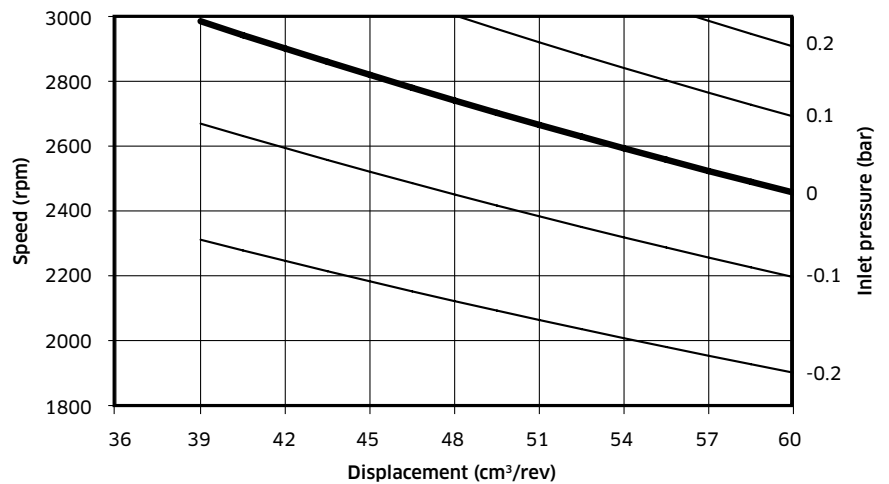

Performance Note:

All performance curves are based on the following conditions:

- 1,500 rpm
- ISO VG46 mineral oil
- 50°C oil temperature
- Atmospheric inlet condition (0 bar)

2-3 Performance Data (cont)

K3VL80

◆ Pump Efficiency (%)

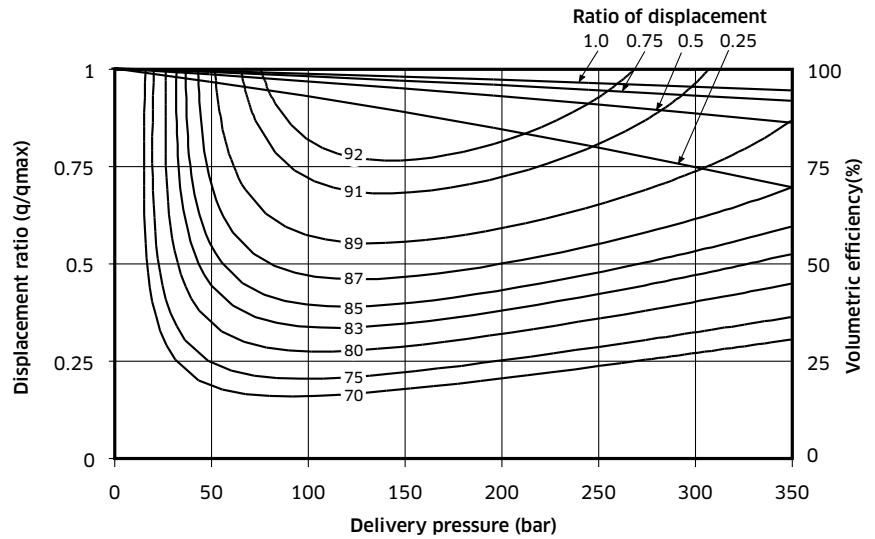

◆ Self Priming Capability

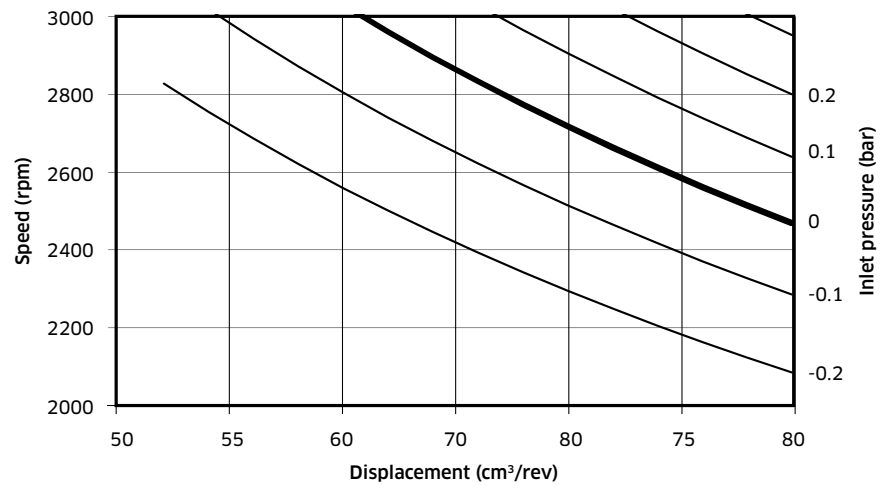

Performance Note:

All performance curves are based on the following conditions:

- 1,500 rpm
- ISO VG46 mineral oil
- 50°C oil temperature
- Atmospheric inlet condition (0 bar)

2-3 Performance Data (cont)

K3VL112

◆ Pump Efficiency (%)

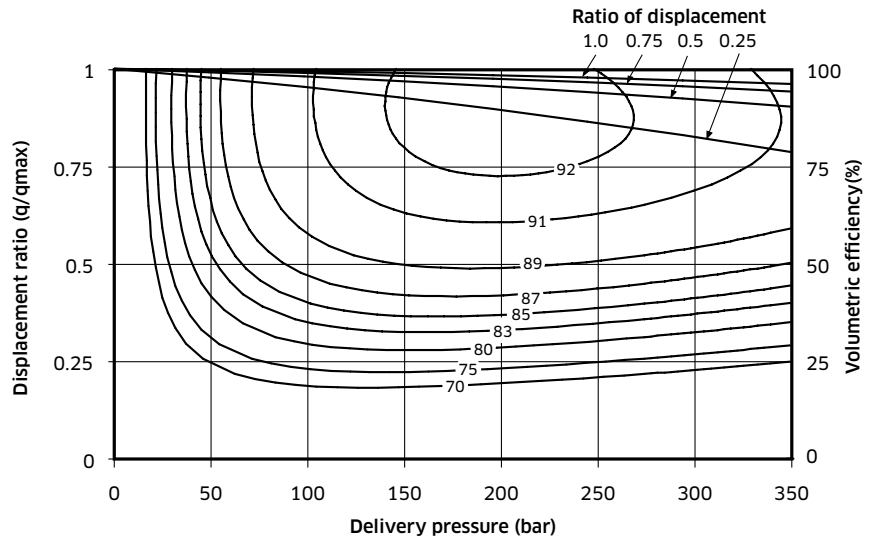

◆ Self Priming Capability

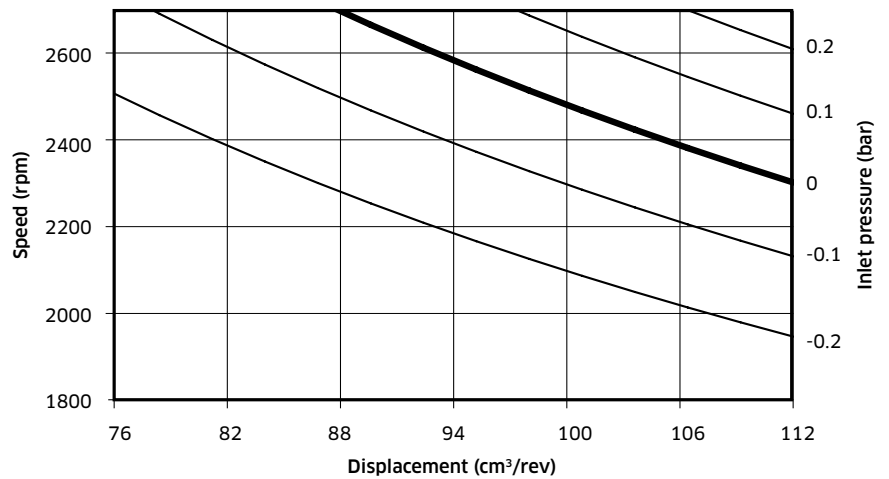

Performance Note:

All performance curves are based on the following conditions:

- 1,500 rpm
- ISO VG46 mineral oil
- 50°C oil temperature
- Atmospheric inlet condition (0 bar)

2-3 Performance Data (cont)

K3VL140

◆ Pump Efficiency (%)

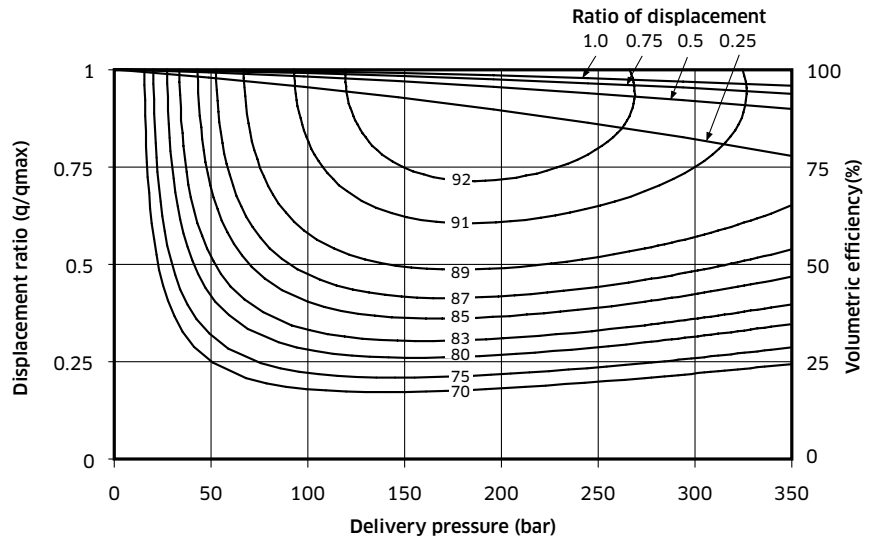

◆ Self Priming Capability

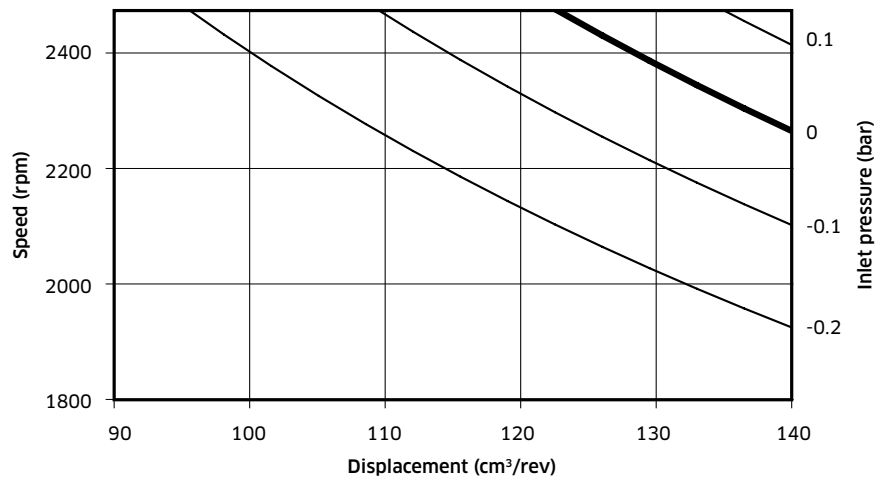

Performance Note:

All performance curves are based on the following conditions:

- 1,500 rpm
- ISO VG46 mineral oil
- 50°C oil temperature
- Atmospheric inlet condition (0 bar)

2-3 Performance Data (cont)

K3VL200

◆ Pump Efficiency (%)

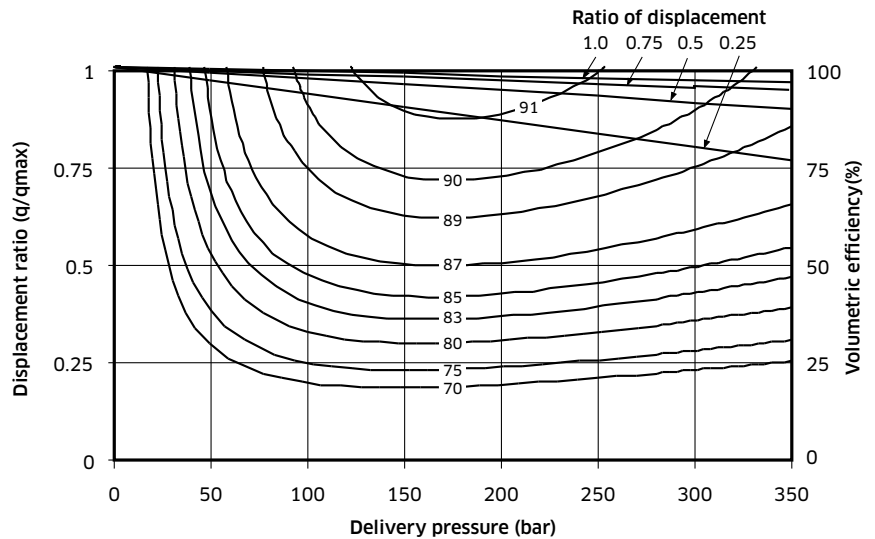

◆ Self Priming Capability

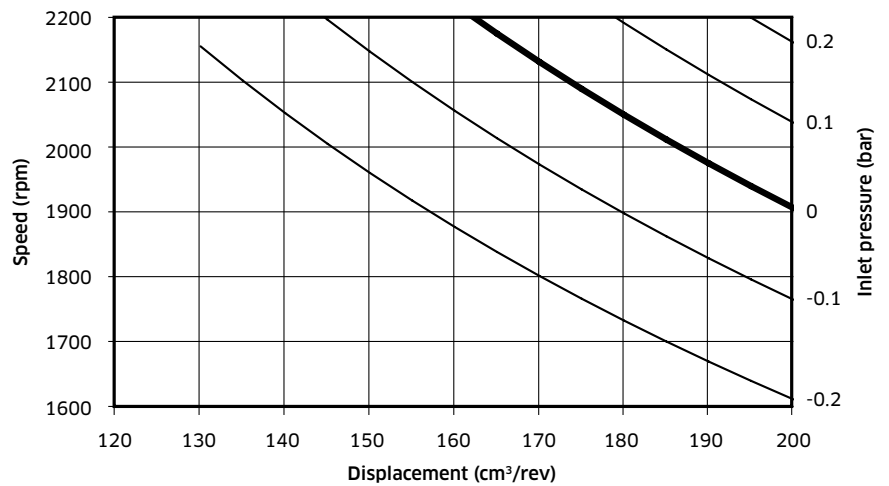

Performance Note:

All performance curves are based on the following conditions:

- 1,500 rpm
- ISO VG46 mineral oil
- 50°C oil temperature
- Atmospheric inlet condition (0 bar)

2-4 Radial Loading Capacity

No axial shaft loading possible Radial loading is achievable but in specific orientation:-

Radial shaft loading can be allowed provided that its orientation is such that the front bearing takes the additional load (See diagram below).

Note: In this case bearing life will be reduced.

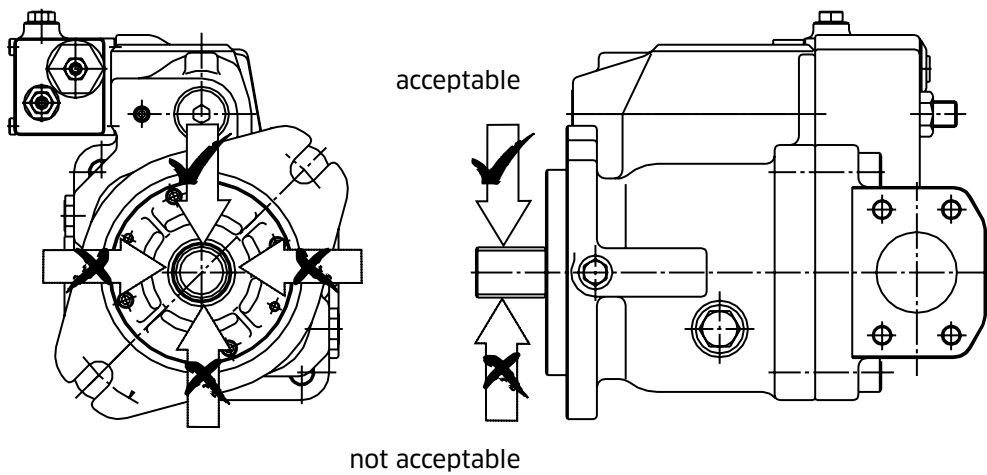

2-5 Functional Description of Regulator

Key to Hydraulic Circuit Annotations	
Annotations	Description
A	Main pump delivery
A1	Auxiliary pump delivery
B1	Gear pump inlet
B	Main pump inlet
Dr	Drain
Pc	Remote pilot port, Pressure compensator
Pi	Pilot port displacement control
PL	Load sense port
Tair	Air bleed port

Notes: A customer supplied gear pump is recommended for all displacement control options. Hydraulic circuit diagrams illustrate the attached gear pump when required.

Regulator Code	Control Curves	Hydraulic Circuit
<p>L0/L1 Load Sense and Pressure Cut-off</p> <p>Pump displacement is controlled to match the flow requirement as a function of the system differential pressure (load pressure vs delivery pressure). In addition, there is a pressure cut off function incorporated into the control. With the L1 option, the bleed-off orifice R4 is plugged.</p>		
<p>LN Load Sense and Pressure Cut-off with Integrated Unloading Valve (Normally Closed)</p> <p>An integrated unloading valve is sandwiched between the Load Sense regulator and pump to effectively de-stroke the swashplate when an electric signal is provided.</p>		

2-5 Functional Description of Regulator (cont)

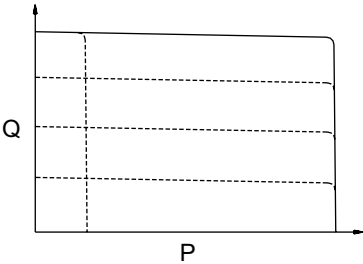
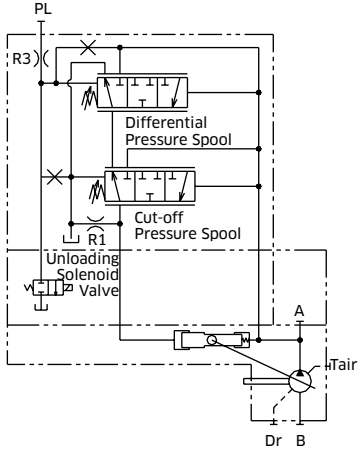
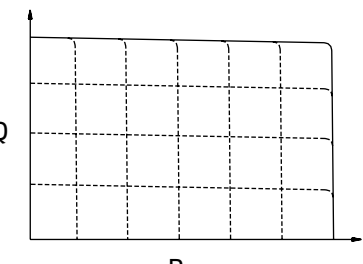
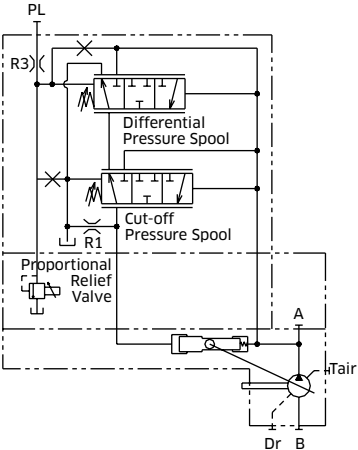
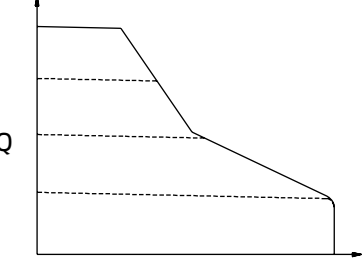
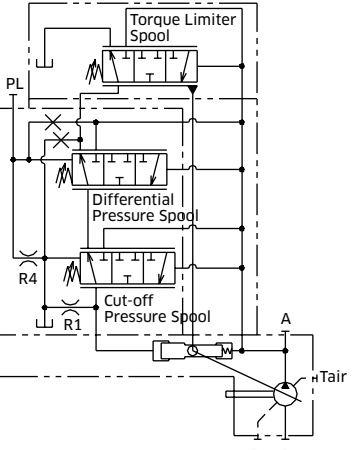
Regulator Code	Control Curves	Hydraulic Circuit
<p>LM Load Sense and Pressure Cut-off with Integrated Unloading Valve (Normally Open)</p> <p>An integrated unloading valve is sandwiched between the Load Sense regulator and the pump. An electrical signal must be provided to prevent the Load Sense line from draining.</p>		
<p>LV Load Sense and Pressure Cut-off with Integrated Proportional Relief Valve</p> <p>An integrated proportional relief valve is sandwiched between the Load Sense regulator and pump to control the maximum pressure setting by varying an electric signal to the valve.</p> <p>A separate amplifier is required.</p>		
<p>L0/1 Load Sense and Pressure Cut-off with Torque Limiting</p> <p>L0/L1 control functions as previously noted. In response to a rise in delivery pressure the swashplate angle is decreased, restricting the input torque. This regulator prevents excessive load against the prime mover.</p> <p>The torque limit control module is comprised of two springs that oppose the spool force generated by the system pressure. By turning an outer and inner spring adjustment screw, the appropriate input torque limit can be set.</p>		

2-5 Functional Description of Regulator (cont)

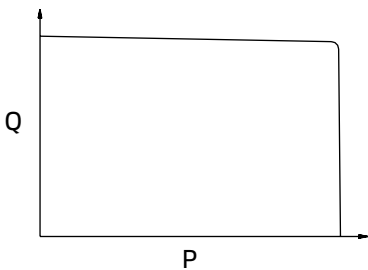
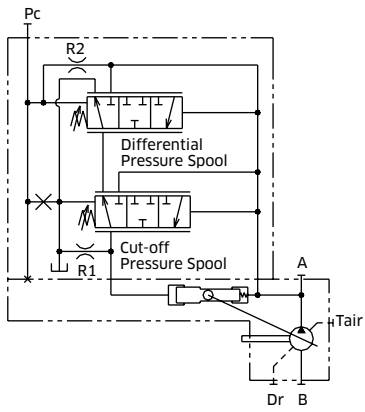
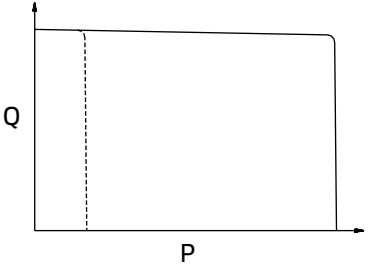
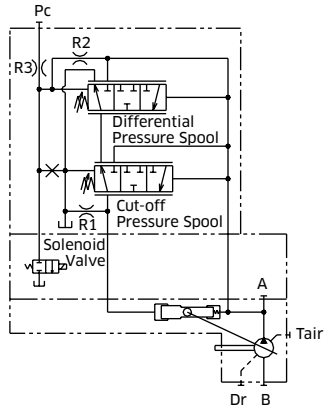
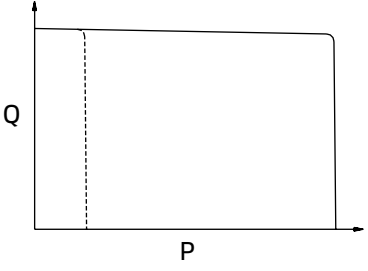
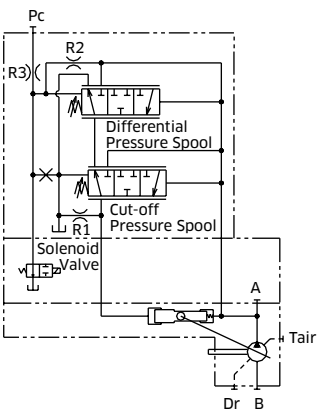
Regulator Code	Control Curves	Hydraulic Circuit
<p>P0 Pressure Cut-off</p> <p>As system pressure rises to the cut-off setting, the swashplate de-strokes to prevent the system pressure from exceeding the compensator setting. It is imperative that a safety relief valve be installed in the system.</p> <p>Note: By connecting the Pc port to a remote pressure control, variable pump pressure control can be achieved.</p>		
<p>PN Pressure Cut-off with Integrated Unloading Valve (Normally Closed)</p> <p>An integrated unloading valve is sandwiched between the Pressure Cut-off regulator and pump to effectively de-stroke the swashplate when an electric signal is provided.</p>		
<p>PM Pressure Cut-off with Integrated Unloading Valve (Normally Open)</p> <p>An integrated unloading valve is sandwiched between the Pressure Cut-off regulator and the pump.</p> <p>An electrical signal must be provided to prevent the Pc line from draining.</p>		

2-5 Functional Description of Regulator (cont)

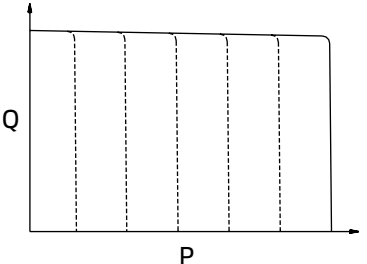
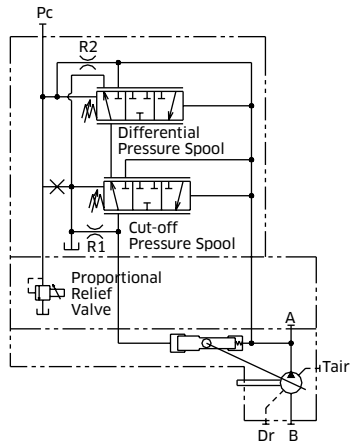
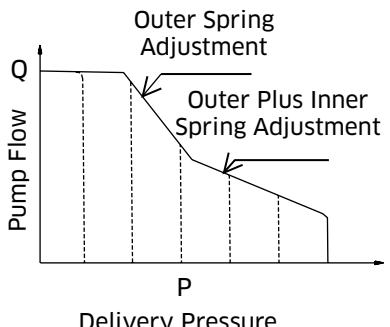
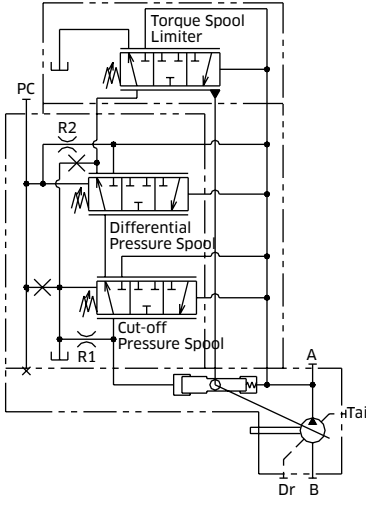
Regulator Code	Control Curves	Hydraulic Circuit
<p>PV Pressure Cut-off with Integrated Proportional Relief Valve</p> <p>An integrated proportional relief valve is sandwiched between the Pressure Cut-off regulator and the pump to control the maximum pressure setting by varying an electric signal to the valve.</p> <p>A separate amplifier is required.</p>		
<p>P0/1 Pressure Cut-off with Torque Limiting</p> <p>P0/1 control functions as previously noted. In response to a rise in delivery pressure the swashplate angle is reduced, restricting the input torque. This regulator prevents excessive load against the prime mover.</p> <p>The torque limit control module is comprised of two springs that oppose the spool force generated by the system pressure. By turning an outer and inner spring adjustment screw, the appropriate input torque limit can be set.</p> <p>Note: By connecting the Pc port to a remote pressure control, variable pump pressure control can be achieved.</p>		

2-5 Functional Description of Regulator (cont)

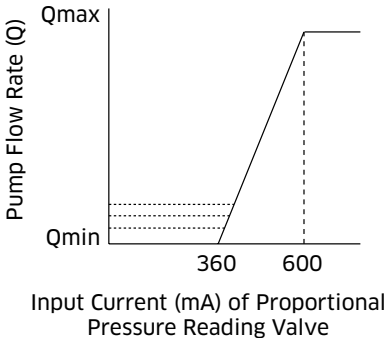
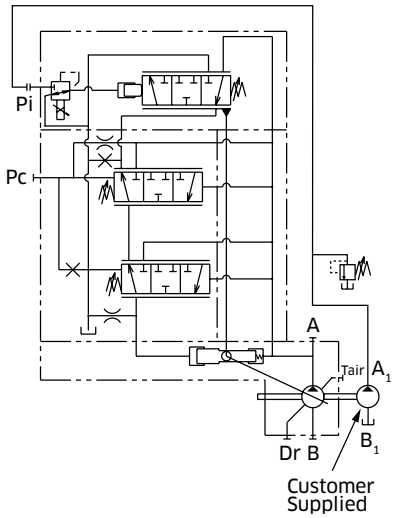
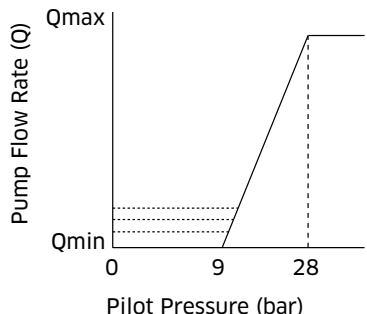
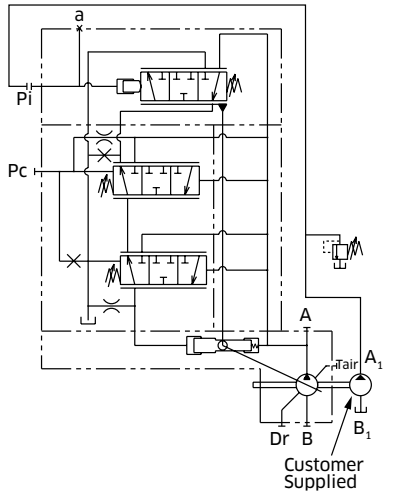
Regulator Code	Control Curves	Hydraulic Circuit
<p>/1-E0 Electrical Displacement Control</p> <p>Varying the input current signal to the pump controller's electronic proportional pressure reducing valve (PPRV) allows the user to control the pump displacement. As the current signal to the PPRV increases, the pump displacement increases proportionally.</p> <p>Note: An external pressure supply of 40 bar is required at the Pi Port (50 bar max).</p>		
<p>/1-Q0 Pilot Operated Displacement Control</p> <p>Varying the input pressure signal to the Pi port allows the user to control the pump displacement. As the pressure signal to the Pi increases, the pump displacement increases proportionally.</p>		

2-6 Torque Limiter Settings

The following tabulations show the power limitation at various electric motor speeds for a specific frame size of pump. When selecting a control setting please ensure that the power limitation of a particularly sized electric motor to your national standard is not exceeded.

K3VL45				
KW	970	1150	1450	1730
3.7	S3	S4	-	-
5.5	L3	S1	S3	S4
7.5	L1	L2	L4	S2
11	M1	M3	L1	L2
15	H3	H4	M2	M4
18.5	-	H2	H4	M2
22	-	-	H3	H4
30	-	-	-	H1
37	-	-	-	-
45	-	-	-	-
55	-	-	-	-
75	-	-	-	-
90	-	-	-	-
110	-	-	-	-
132	-	-	-	-

K3VL60				
KW	970	1150	1450	1730
3.7	-	-	-	-
5.5	S2	S2	-	-
7.5	L4	S1	S3	-
11	M4	L2	S1	S2
15	M2	M3	L2	L3
18.5	H2	M1	M3	L1
22	-	H2	M2	M3
30	-	-	H2	H3
37	-	-	-	H1
45	-	-	-	-
55	-	-	-	-
75	-	-	-	-
90	-	-	-	-
110	-	-	-	-
132	-	-	-	-

K3VL80				
KW	970	1150	1450	1730
3.7	-	-	-	-
5.5	S2	S4	-	-
7.5	L6	S1	S3	-
11	L2	L4	L6	S1
15	M4	L1	L3	L5
18.5	M1	M3	L1	L3
22	H3	M1	M4	L1
30	H1	H2	H4	M2
37	-	-	H2	H4
45	-	-	H1	H2
55	-	-	-	H1
75	-	-	-	-
90	-	-	-	-
110	-	-	-	-
132	-	-	-	-

K3VL112				
KW	970	1150	1450	1730
3.7	-	-	-	-
5.5	-	-	-	-
7.5	S5	S6	-	-
11	S1	S3	S5	S6
15	L3	L4	S2	S4
18.5	M4	L2	L4	S2
22	M2	M4	L3	L4
30	H4	M1	M3	L1
37	H2	H3	M1	M3
45	-	H2	H4	M1
55	-	-	H2	H4
75	-	-	-	H1
90	-	-	-	-
110	-	-	-	-
132	-	-	-	-

K3VL140				
KW	970	1150	1450	1730
3.7	-	-	-	-
5.5	-	-	-	-
7.5	-	-	-	-
11	S2	S4	-	-
15	L6	S1	S3	-
18.5	L3	L5	S1	S3
22	L1	L3	L6	S1
30	M2	M3	L2	L4
37	H4	M1	M3	L2
45	H2	H4	M2	M3
55	-	H2	H4	M2
75	-	-	H1	H3
90	-	-	-	H1
110	-	-	-	-
132	-	-	-	-

K3VL200				
KW	970	1150	1450	1730
3.7	-	-	-	-
5.5	-	-	-	-
7.5	-	-	-	-
11	-	-	-	-
15	-	-	-	-
18.5	S1	-	-	-
22	L4	S1	-	-
30	L2	L3	L5	S2
37	M3	L1	L3	L5
45	M1	M3	L2	L3
55	H5	M1	M3	L2
75	H1	H3	H6	M2
90	-	H1	H4	H6
110	-	-	H2	H4
132	-	-	-	H2

Note: For S Rating Spring Settings - Please consult KPM UK.

2-6 Torque Limiter Settings (cont)

◆ Torque Limiter Settings - Other Applications

Where the pump is driven by an engine then the following tabulation should be used to determine the necessary torque limiter setting for a particular pump frame size. Care should be taken for allowing for any other systemic power losses in the circuit to prevent potential Engine stall.

Input Torque	K3VL Frame Size					
	45	60	80	112	140	200
Nm						
30	S4	-	-	-	-	-
36	S3	-	-	-	-	-
41	S2	-	-	-	-	-
46	S1	S4	S4	-	-	-
49	L4	S3	S3	-	-	-
53	L3	S2	S2	-	-	-
61	L2	S1	S1	S6	-	-
73	L1	L4	L6	S5	-	-
82	M4	L3	L5	S4	-	-
91	M3	L2	L4	S3	S4	-
100	M2	L1	L3	S2	S3	-
107	M1	M4	L2	S1	S2	-
121	H4	M3	L1	L4	S1	-
146	H3	M2	M4	L3	L6	-
154	H2	M1	M3	L2	L5	-
163	H1	H3	M2	L1	L4	S2
182	-	H2	M1	M4	L3	S1
200	-	H1	H4	M3	L2	L5
216	-	-	H3	M2	L1	L4
246	-	-	H2	M1	M3	L3
298	-	-	H1	H4	M2	L2
307	-	-	-	H3	M1	L1
367	-	-	-	H2	H4	M3
409	-	-	-	H1	H3	M2
450	-	-	-	-	H2	M1
492	-	-	-	-	H1	H6
540	-	-	-	-	-	H5
610	-	-	-	-	-	H4
618	-	-	-	-	-	H3
711	-	-	-	-	-	H2
752	-	-	-	-	-	H1

2-7 Installation

◆ Pump Mounting Options

Drain line

It is the preferred option to mount the pump with the case drain piping initially rising above the pump before continuing to the tank. Do not connect the drain line to the inlet line.

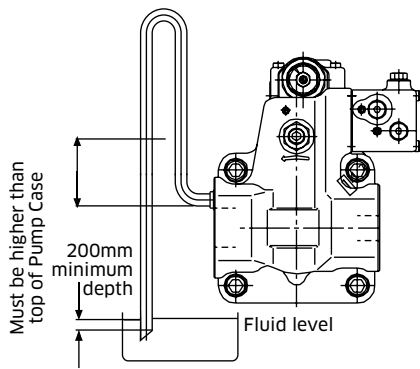

Cautions

- A) Inlet and drain pipes must be immersed by 200 mm minimum from the lowest level under operating conditions.
- B) Height from the oil level to the centre of the shaft must be within 1 meter maximum. (consult KPM UK).
- C) The oil in the pump case must be refilled when the pump has not been operated for one month or longer.

The uppermost drain port should be used and the drain piping should be equal or larger in size than the drain port to minimise pressure in the pump case. The pump case pressure should not exceed 1 bar as shown in the illustration below. (Peak pressure should never exceed 4 bar.)

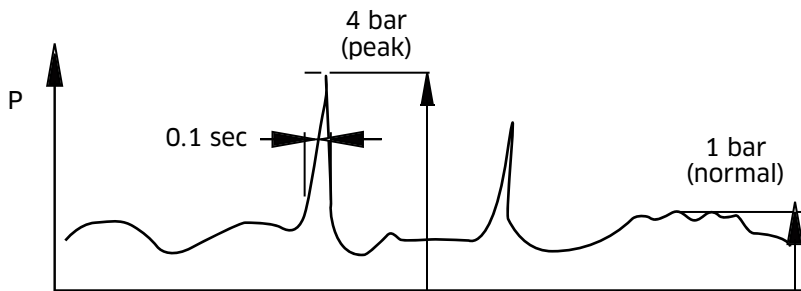

Mounting the Pump Above the Tank

Suction line

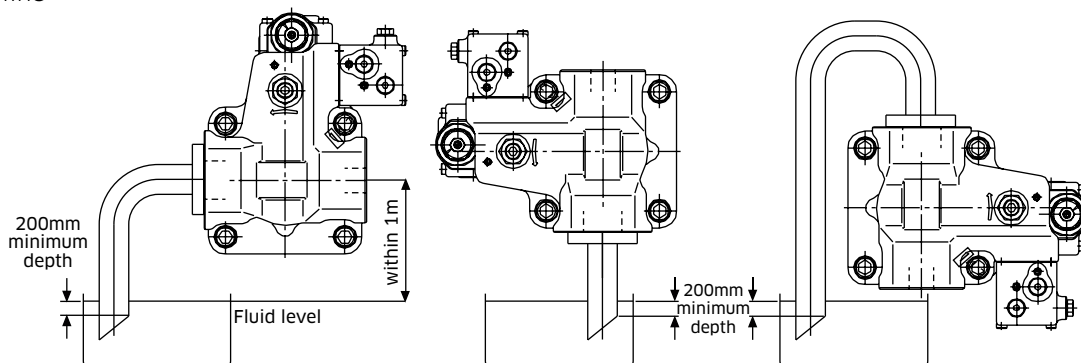

2-7 Installation (cont)

Mounting the Pump Vertically (shaft up)

Note: Both the Tair and one case drain port must be used.

For applications requiring vertical installation (shaft up) please remove the Tair bleed plug and connect piping as shown in the illustration below.

When installing the pump in the tank and submerged in the oil, open the drain port and Tair bleed port to provide adequate lubrication to the internal components. See illustration [a].

The oil level in the tank should be higher than the pump-mounting flange as shown in illustration [a] below. If the oil level in the tank is lower than the pump mounting flange then forced lubrication is required through the Tair bleed port 1 ~ 2 l/min.

When installing the pump outside the tank run piping for the drain and Tair bleed ports to tank (see illustration [c]). If the drain or Tair bleed piping rise above the level of oil (see illustration [b]) fill the lines with oil before operation. motor to your national standard is not exceeded.

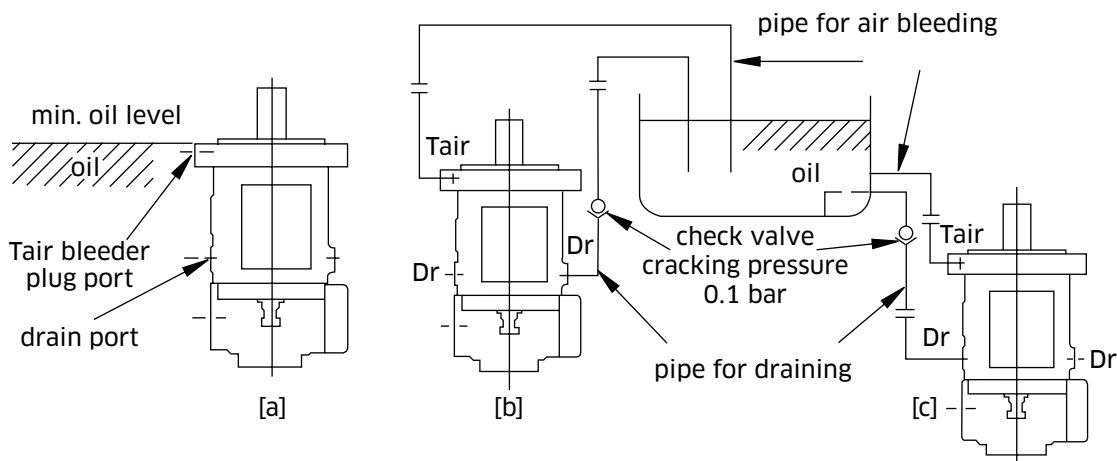

A check valve with cracking pressure of 0.1 bar should be fitted to the case drain line as shown.

2-7 Installation (cont)

◆ Drive Shaft Coupling

Use a flexible coupling to connect the pump shaft to an engine flywheel or electric motor shaft. Alignment should be within 0.05 mm TIR as shown in the illustration below.

Do not apply any radial or axial loading to the pump shaft. For applications where radial or side loads exist please contact KPM UK for recommendations.

Do not force the coupling on or off the pump shaft. Use the threaded hole in the end of the pump shaft to fix or remove the coupling.

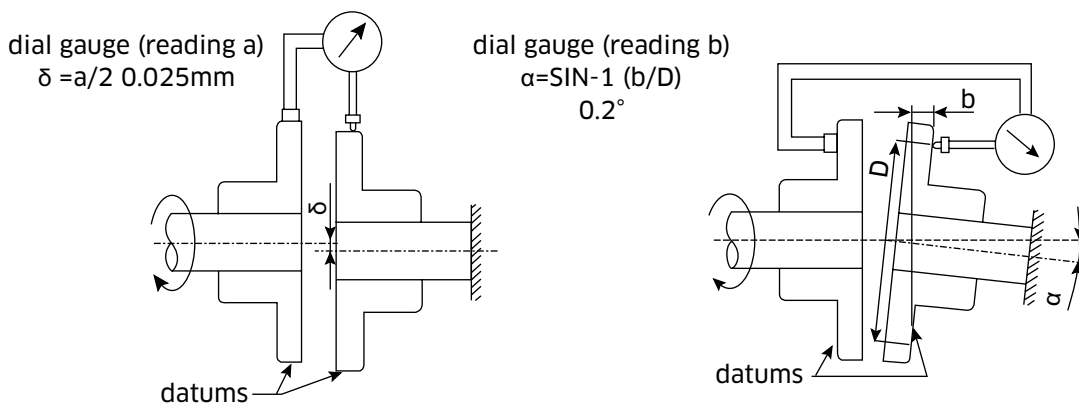

For engine drives a split type pinch bolt drive flange and flexible coupling is recommended.

Moment of Inertia and Torsional Stiffness

Frame Size	Moment of Inertia $GD^2 \text{ (kgf}\cdot\text{m}^2)$	Torsional Stiffness $\text{(N}\cdot\text{m/rad)}$
K3VL28	8.36×10^{-3}	2.20×10^4
K3VL45	1.54×10^{-2}	3.59×10^4
K3VL60	1.54×10^{-2}	3.59×10^4
K3VL80	2.92×10^{-2}	4.83×10^4
K3VL112	8.06×10^{-2}	9.33×10^4
K3VL140	8.06×10^{-2}	9.33×10^4
K3VL200	1.83×10^{-2}	1.54×10^5
K3VL200H	1.83×10^{-2}	1.54×10^5

2-7 Installation (cont)

Through Drive Limitations

Pump over all length (mm)	
Frame size	Single pump type N
K3VL28	219
K3VL45	244
K3VL60	244
K3VL80	272
K3VL112	307.5
K3VL140	307.5
K3VL200	359
K3VL200H	424

Frame size	Pump approx weight (Kg)	
	Single pump type N	
	Without Torque Limitor	With Torque Limitor
K3VL28	22	na
K3VL45	28	30
K3VL60	28	30
K3VL80	38	40
K3VL112	69	71
K3VL140	69	71
K3VL200	103	105
K3VL200H	142	140

Frame size	Pump CofG from mount (mm)
	Single pump type N
K3VL28	115
K3VL45	120
K3VL60	120
K3VL80	130
K3VL112	150
K3VL140	150
K3VL200	190
K3VL200H	223

Frame size	Maximum Permissible Bending Moment (Nm)
K3VL28	137
K3VL45	137
K3VL60	137
K3VL80	244
K3VL112	462
K3VL140	462
K3VL200	930
K3VL200H	930

Adaptor Kits Weight & Width			
Frame size	Adaptor Kit	Weight Kg	Width mm
K3VL28	SAE 'A'	0	0
	SAE 'B'	2	20
K3VL45 & 60	SAE 'A'	0	0
	SAE 'B' & 'BB'	2	20
K3VL80	SAE 'A'	0	0
	SAE 'B' & 'BB'	3	20
	SAE 'C', 'CC' & 'C4'	4	24.5
K3VL112 & 140	SAE 'A'	0	0
	SAE 'B' & 'BB'	3	25
	SAE 'C', 'CC' & 'C4'	5	30
	SAE 'D'	10	43
K3VL200	SAE 'A'	1	6
	SAE 'B' & 'BB'	8	25
	SAE 'C', 'CC' & 'C4'	8	30
	SAE 'D'	10	38
	SAE 'E'	15	38

2-7 Installation (cont)

Electrical and Pilot Operated Displacement Control (Type E0, Q0)

Type E0 - In order for the electronic displacement control to function, a minimum pilot pressure of 40 bar must be supplied to the Pi port on the regulator. A gear pump attached to the rear of the K3VL pump or an external pressure source can be used to provide the required pilot pressure.

Type Q0 - In order for the Q0 displacement control to function, a variable pilot pressure between 0 and 40 bar is required.

Proportional Pressure Reducing Valve Specification

Maximum Pilot Pressure	: 50 bar (If higher pressure required contact KPM UK)	Electrical specifications,	
Max Flow	: 10 l/min	Rated current	: 700 mA
Hydraulic oil	: Mineral oil	Recommended dither	: 80 Hz / 200 mAp-p
Oil temp range	: -20~+90°C	Coil resistance	: 17.5 Ω(at 20°C)
Viscosity range	: 5~500 cst	Ambient temperature range	: -30~+95°C
Allowable contamination	: NAS grade 10 and below	Water resistance	: According to JIS D 0203 S2

3 Dimensions

3-1 K3VL28 Installation

◆ K3VL28 with Cut-Off / Load Sense Control (Clockwise Rotation)

Inlet and outlet ports reversed for counter clockwise rotation.

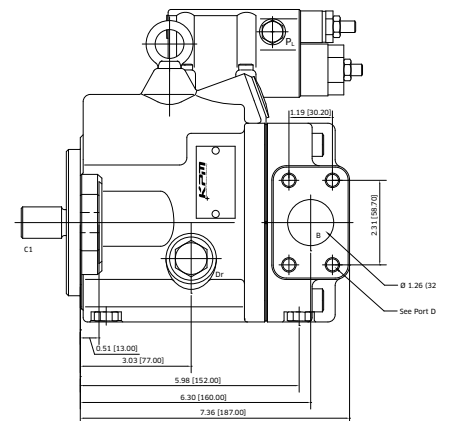
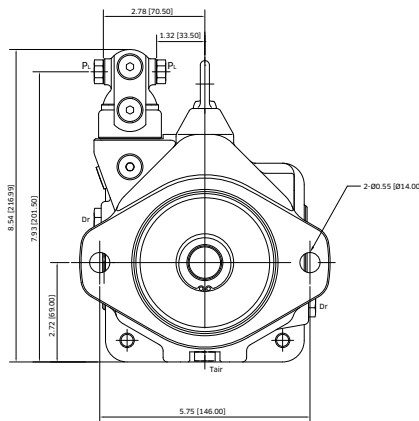
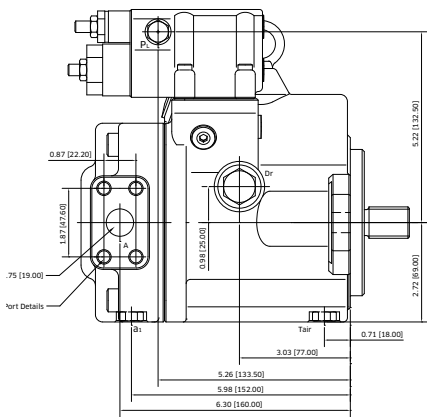
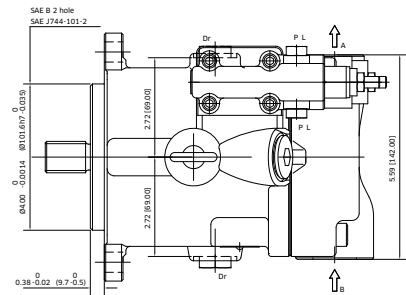
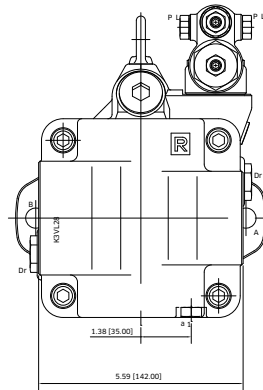

Port Details

Des.	Port Name	Port Size and Description	Tightening Torque (Nm)
A	Delivery Port	¾ SAE J518C Code 61 (5,000 psi)	57
		Unified Thread Type 'S' ¾-16-2B(0.66")	
B	Inlet Port	1¼ SAE J518 Code 61 (3,000 psi)	57
		Unified Thread Type 'S' 7/16-16-2B(0.66")	
Dr	Drain Port	½ O-Ring Boss -8 SAE J1926/1 (¾"-16 UNF-2B)	98
P	PO/LO Control Port	¼ O-Ring Boss -4 SAE J1926/1 (7/16"-20 UNF-2B)	12
T	Air Bleed Port	¼ O-Ring Boss -4 SAE J1926/1 (7/16"-20 UNF-2B)	12
a	GaugePort	¼ O-Ring Boss -4 SAE J1926/1 (7/16"-20 UNF-2B)	12

3-1 K3VL28 Installation (cont)

◆ K3VL28 Shaft & Through Drive Options

Model Code Option 'K' Shaft

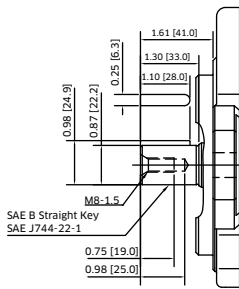

Model Code Option 'S' Shaft

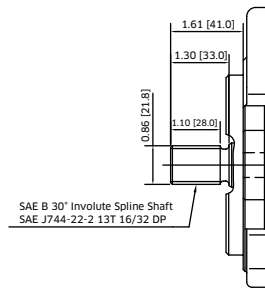

Through Drive SAE 'A'

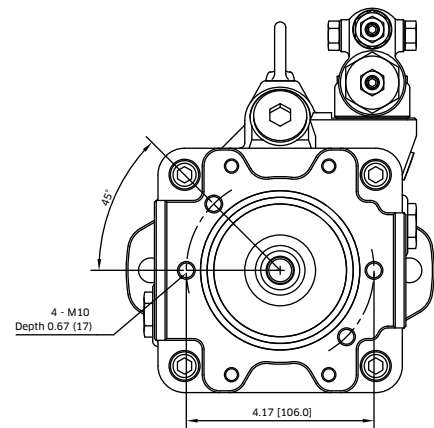
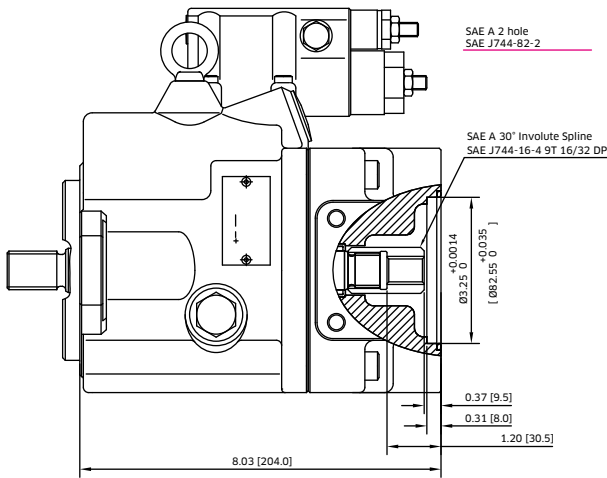

Through Drive SAE 'B'

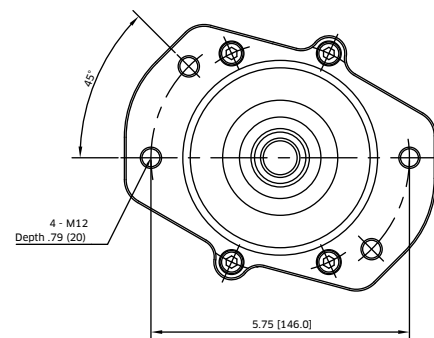
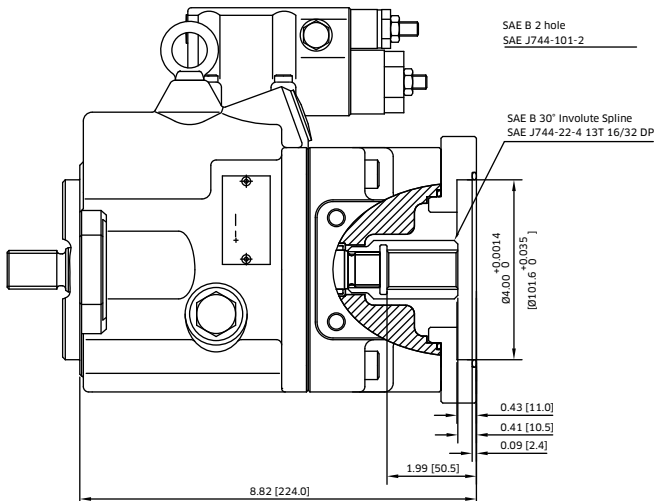

3-1 K3VL28 Installation (cont)

◆ K3VL28 Adaptor Kits

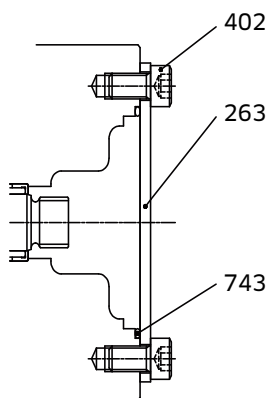

Cover Kit

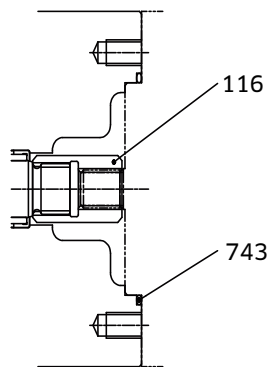

SAE 'A' T/D Kit

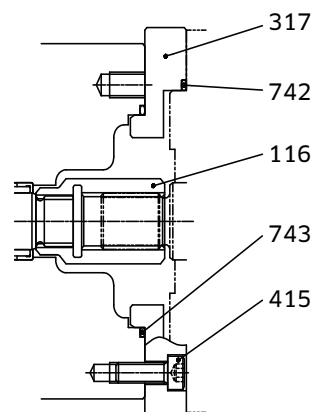

SAE "B" T/D KIT

NO.	Part Name	Qty	Cover Kit	SAE 'A' T/D Kit	SAE 'B' T/D Kit
-	T/D Kit	-	29L8TN	29L3TA	29L3TB
743	O-Ring	1	00RBG85	00RBG85	00RBG85
742	O-Ring	1	-	-	00RBG105
415	Screw Hex SHC	4	-	-	OSBM825
402	Screw Hex SHC	2	OSBM1020	-	-
317	Subplate	1	-	-	2924750-0358
314	Cover	1	2924750-0326	-	-
116	Coupling	1	-	2903150-1307	2903150-1325

3-2 K3VL45/60 Installation

◆ K3VL45/60 with Cut-Off / Load Sense Control & Torque Limit Module (Clockwise Rotation)

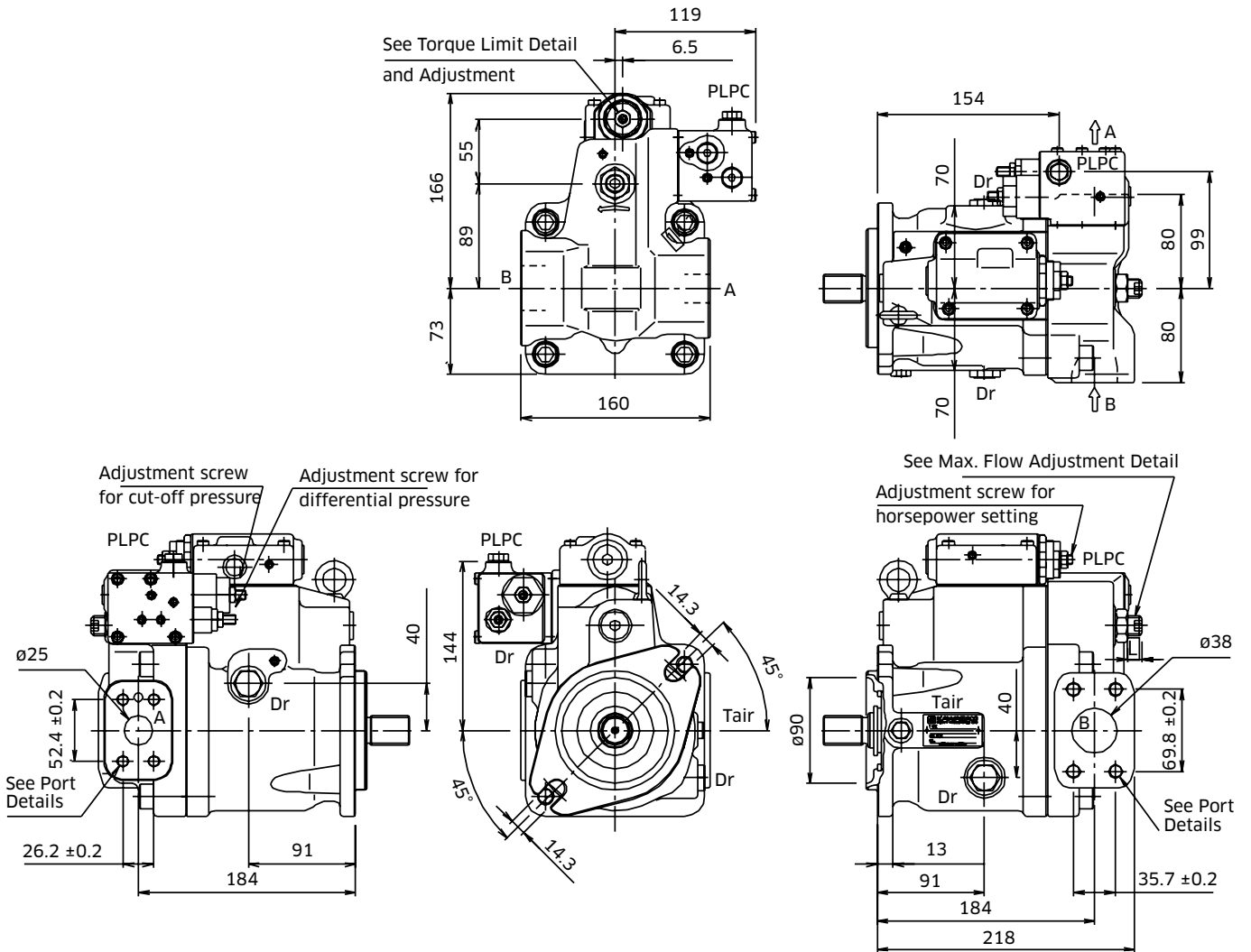

Note: for counter clockwise rotation, the inlet port 'B' and the delivery port 'A' are reversed.

3-2 K3VL45/60 Installation (cont)

◆ K3VL45/60 Mounting Flange and Shaft Options

SAE Type

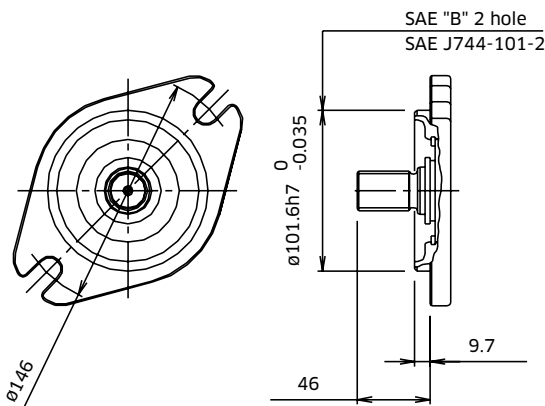

ISO Type

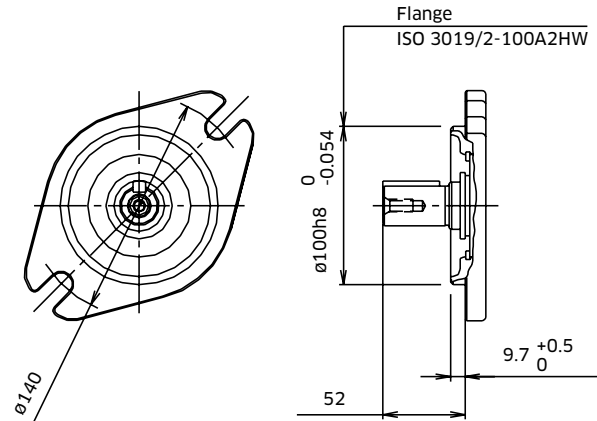

SAE 'BB' Spline Shaft

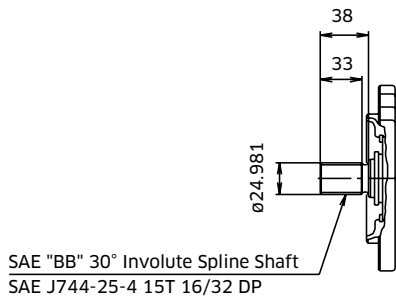

SAE 'BB' Straight Shaft

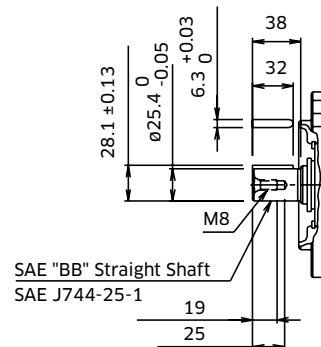

SAE 'B' Spline Shaft

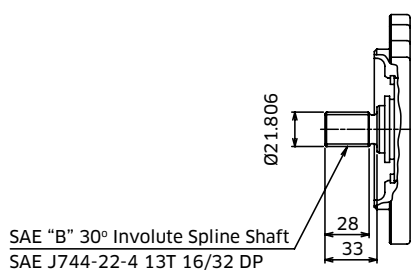

ISO Straight Shaft

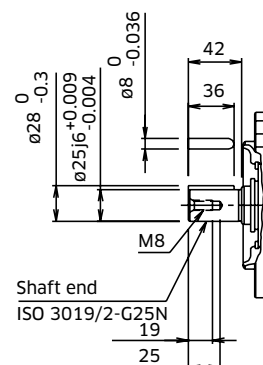

3-2 K3VL45/60 Installation (cont)

◆ K3VL45/60 Rear Port

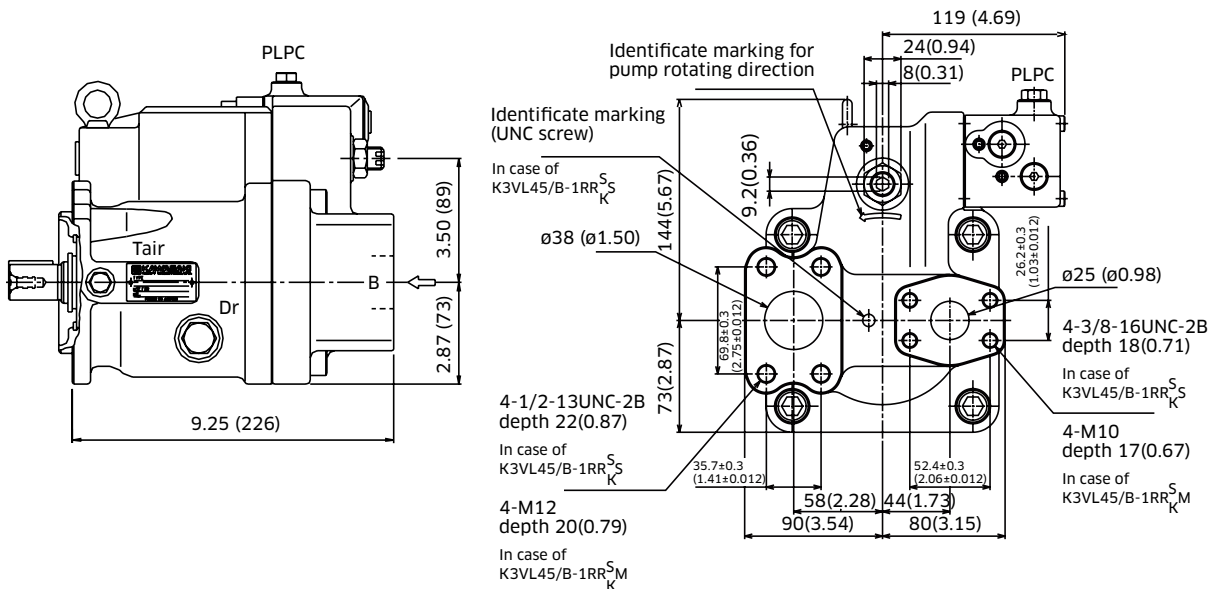

◆ K3VL45/60 Porting Details

Main SAE Flanged Ports

Des.	Port Name	Port Size	Tightening Torque (Nm)	Flange Threads
------	-----------	-----------	------------------------	----------------

UNF Threaded Version ('S' in position 9 of model code)

A	Delivery Port	SAE J518C Std pressure (code 61) 1"	57	3/8-16UNC-2B x 18 mm
B	Suction Port	SAE J518C Std pressure (code 61) 2"	98	1/2-13UNC-2B x 22 mm

Metric Version ('M' in position 9 of model code)

A	Delivery Port	SAE J518C Std pressure (code 61) 1"	57	M10 x 17
B	Suction Port	SAE J518C Std pressure (code 61) 2"	98	M12 x 20

Auxiliary Ports

Des.	Port Name	Port Size	Tightening Torque (Nm)
------	-----------	-----------	------------------------

SAE Version ('S', 'K', or 'T' in position 8 of model)

Dr	Drain Port (x2)	SAE J1926/1 Straight thread O ring boss 1/2" OD Tube 3/4-16UNF-2B	98
PLPC	Load Sensing Port Pressure Control Port	SAE J1926/1 Straight thread O ring boss 1/2" OD Tube 3/4-16UNF-2B	12
Tair	Air Bleeder Port	SAE J1926/1 Straight thread O ring boss 1/4" OD Tube 7/8-20UNF-2B	12

ISO Version ('M' in position 8 of model code)

Dr	Drain Port (x2)	M22 x 1.5 DIN 3852	98
PLPC	Load Sensing Port Pressure Control Port	M14 x 1.5 DIN 3852	25
Tair	Air Bleeder Port	M14 x 1.5 DIN 3852	25

3-2 K3VL45/60 Installation (cont)

◆ K3VL45/60 Through Drive Options

Through Drive 'A'

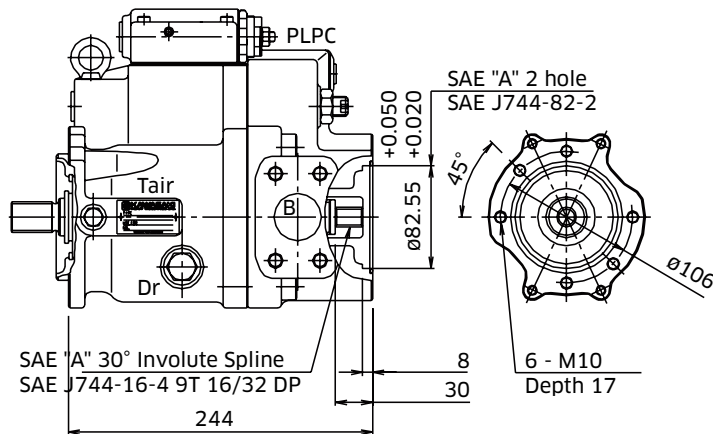

Through Drive 'B'

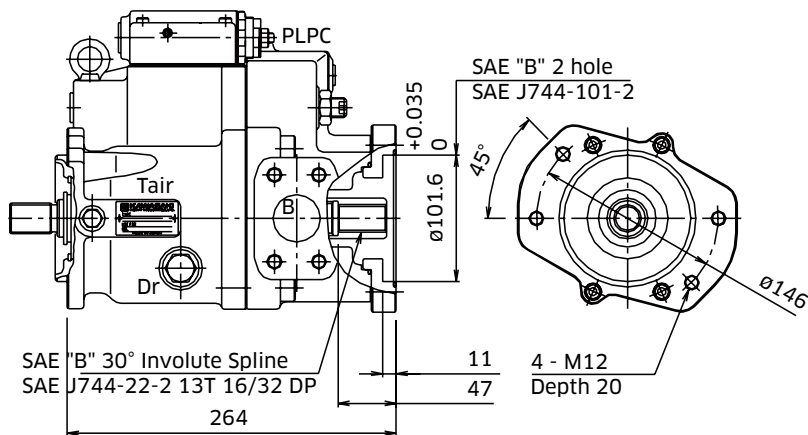

Through Drive 'BB'

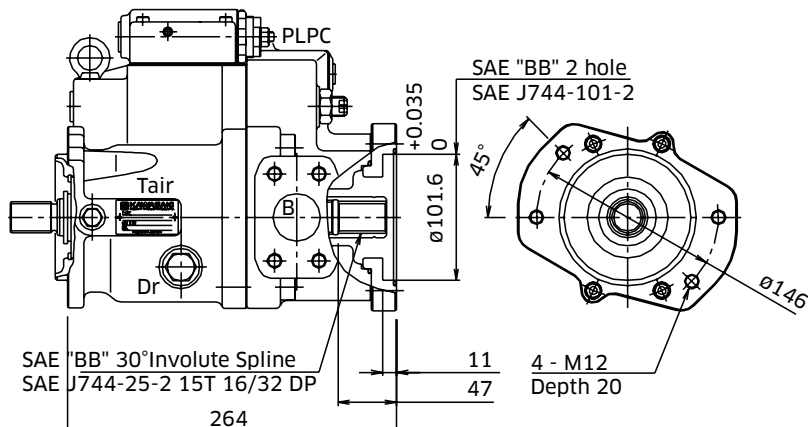

3-2 K3VL45/60 Installation (cont)

◆ K3VL45/60 Adaptor Kits

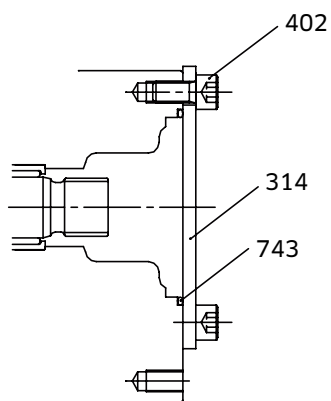

COVER KIT

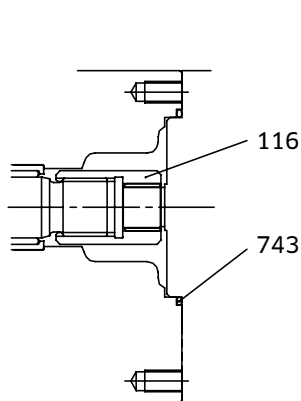

SAE 'A' T/D KIT

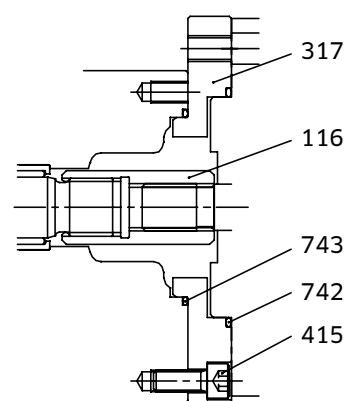

SAE 'B' & 'BB' T/D KIT

NO.	Part Name	Qty	Cover Kit	SAE 'A' T/D Kit	SAE 'B' T/D Kit	SAE 'BB' T/D Kit
-	T/D Kit	-	29L8TN	29L4TA	29L4TB	29L4T2
743	O-Ring	1	00RBG85	00RBG85	00RBG85	00RBG85
742	O-Ring	1	-	-	00RBG105	00RBG105
415	Screw Hex SHC	4	-	-	OSBM825	OSBM825
402	Screw Hex SHC	2	OSBM1020	-	-	-
317	Subplate	1	-	-	2924750-0358	2924750-0358
314	Cover	1	2923150-0316	-	-	-
116	Coupling	1	-	2903150-0264	2903150-0265	2903150-0266

3-3 K3VL80 Installation

◆ K3VL80 with Cut-Off / Load Sense Control & Torque Limit Module (Clockwise Rotation)

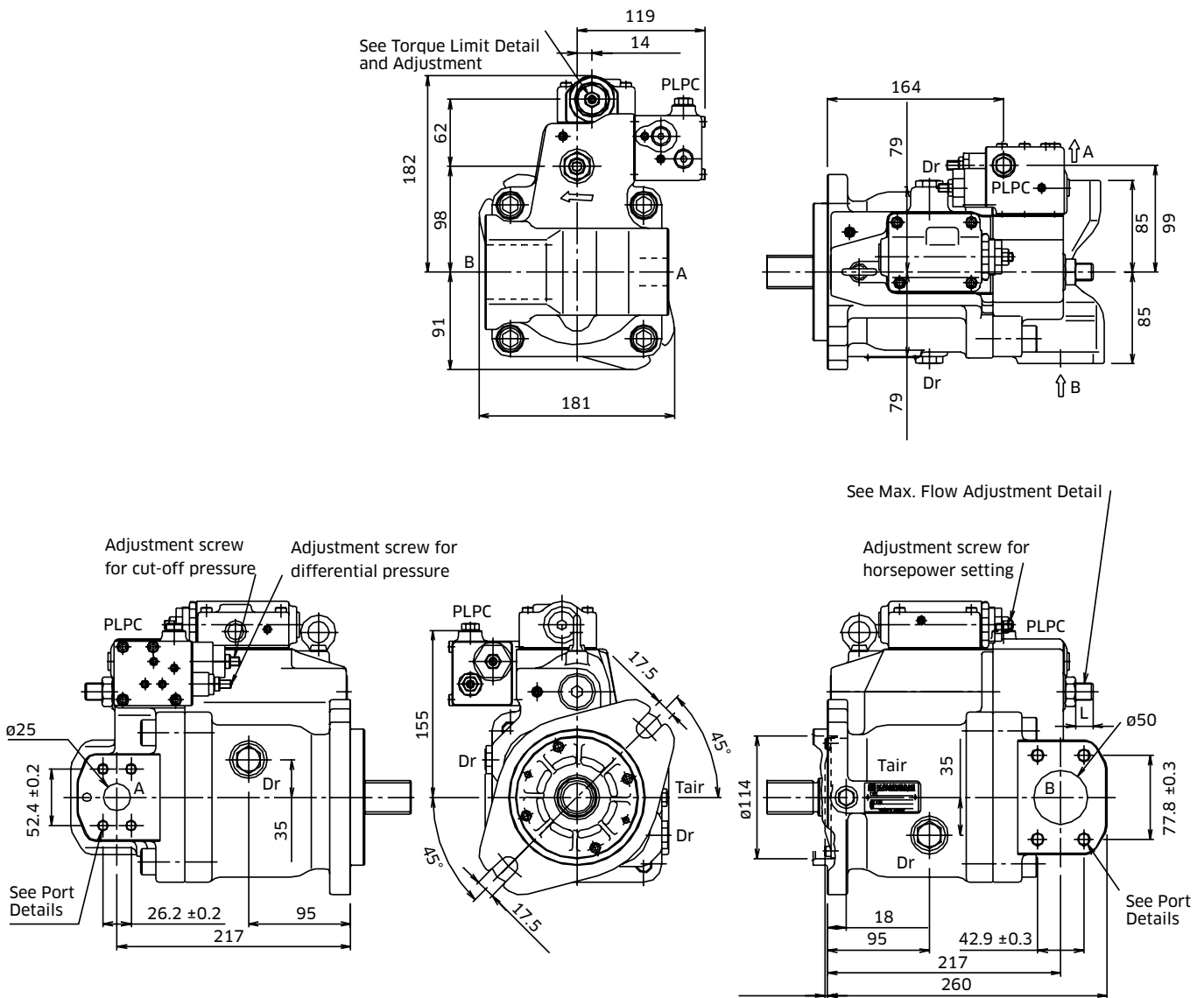

Note: for counter clockwise rotation, the suction port 'B' and the delivery port 'A' are reversed

3-3 K3VL80 Installation (cont)

◆ K3VL80 Mounting Flange and Shaft Options

SAE Type

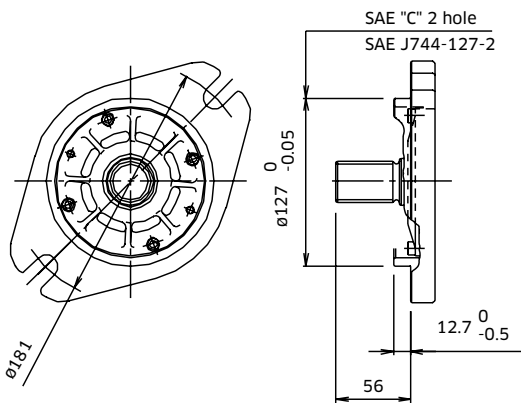

ISO Type

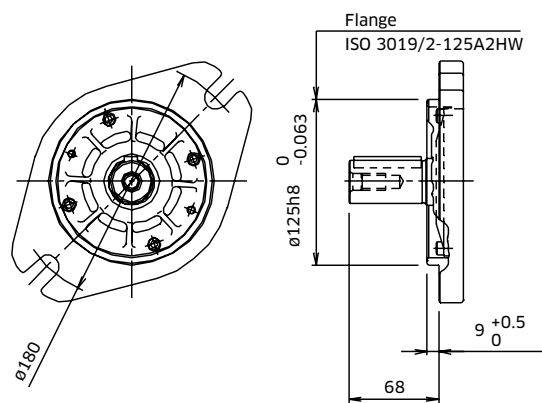

SAE 'C' Spline Shaft

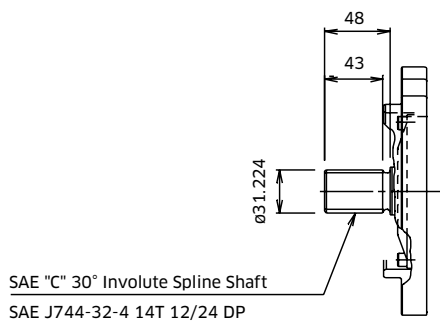

SAE 'C' Straight Shaft

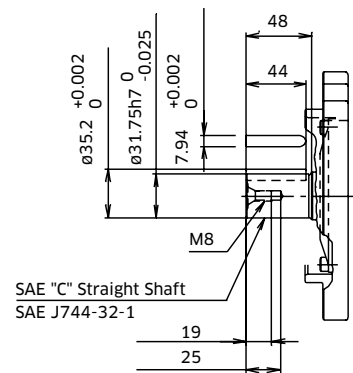

ISO Straight Shaft

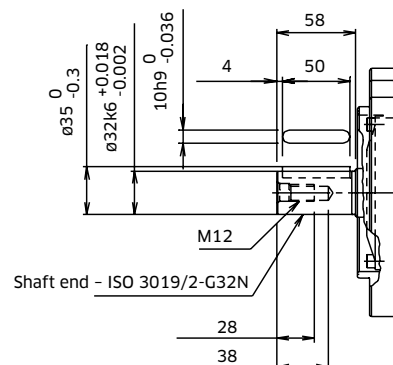

3-3 K3VL80 Installation (cont)

◆ K3VL80 Rear Port

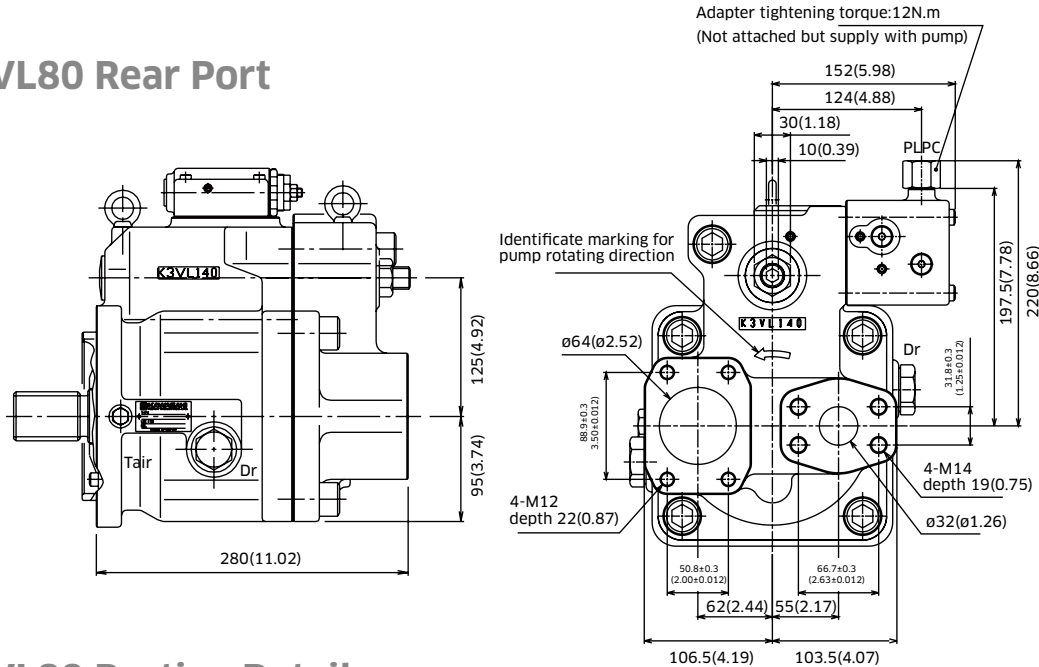

◆ K3VL80 Porting Details

Main SAE Flanged Ports

Des.	Port Name	Port Size	Tightening Torque (Nm)	Flange Threads
------	-----------	-----------	------------------------	----------------

UNF Threaded Version ('S' in position 9 of model code)

A	Delivery Port	SAE J518C Std pressure (code 61) 1"	57	3/8"-16UNC-2B x 18 mm
B	Suction Port	SAE J518C Std pressure (code 61) 2"	98	1/2"-13UNC-2B x 22 mm

Metric Version ('M' in position 9 of model code)

A	Delivery Port	SAE J518C Std pressure (code 61) 1"	57	M10 x 17
B	Suction Port	SAE J518C Std pressure (code 61) 2"	98	M12 x 20

Auxiliary Ports

Des.	Port Name	Port Size	Tightening Torque (Nm)
------	-----------	-----------	------------------------

SAE Version ('S', 'K', or 'T' in position 8 of model)

Dr	Drain Port (x2)	SAE J1926/1 Straight thread O ring boss 1/2" OD Tube 3/4"-16UNF-2B	98
PLPC	Load Sensing Port Pressure Control Port	SAE J1926/1 Straight thread O ring boss 1/2" OD Tube 3/4"-16UNF-2B	12
Tair	Air Bleeder Port	SAE J1926/1 Straight thread O ring boss 1/4" OD Tube 7/8"-20UNF-2B	12

ISO Version ('M' in position 8 of model code)

Dr	Drain Port (x2)	M22 x 1.5 DIN 3852	98
PLPC	Load Sensing Port Pressure Control Port	M14 x 1.5 DIN 3852	25
Tair	Air Bleeder Port	M14 x 1.5 DIN 3852	25

3-3 K3VL80 Installation (cont)

◆ K3VL80 Through Drive Options

Through Drive 'A'

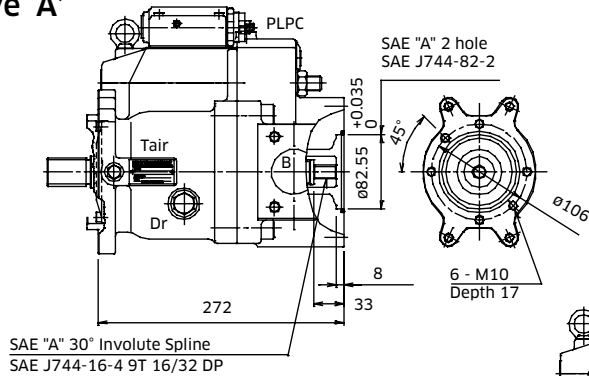

Through Drive 'B'

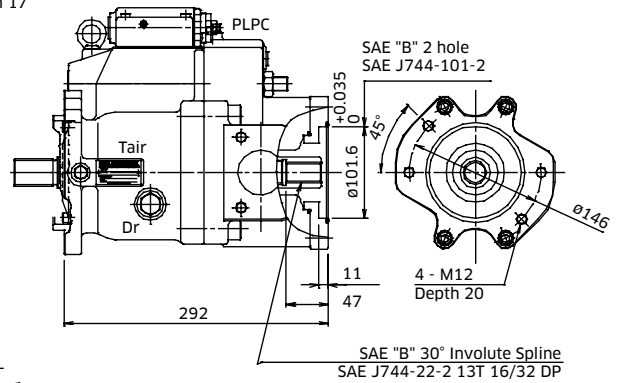

Through Drive 'BB'

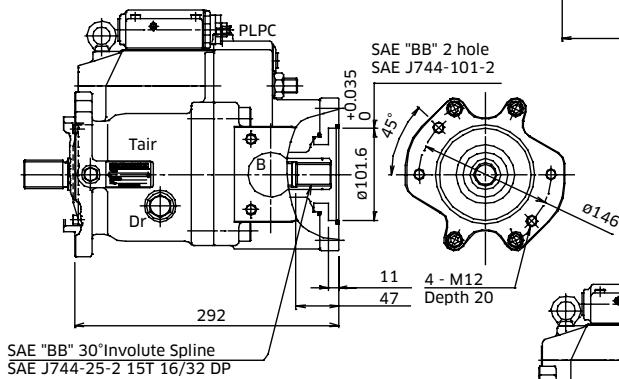

Through Drive 'C'

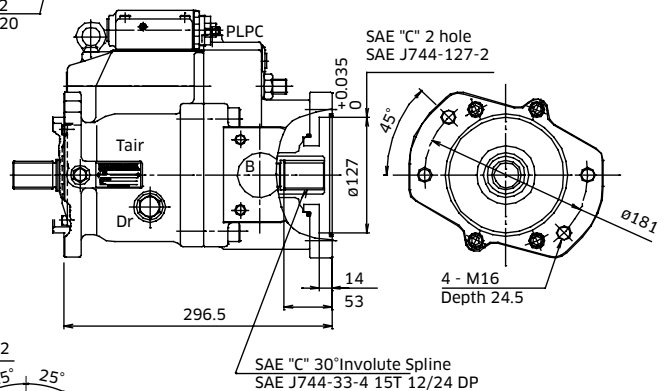

Through Drive 'C4'

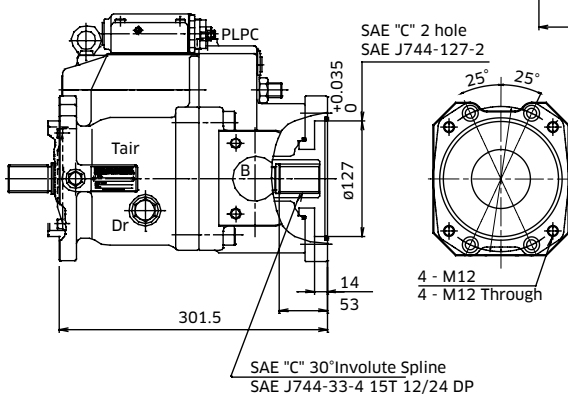

3-3 K3VL80 Installation (cont)

◆ K3VL80 Adaptor Kits

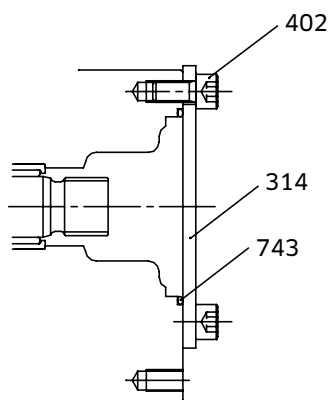

Cover Kit

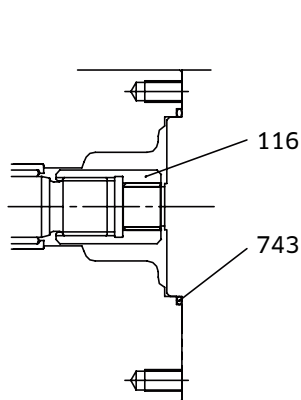

SAE 'A' T/D Kit

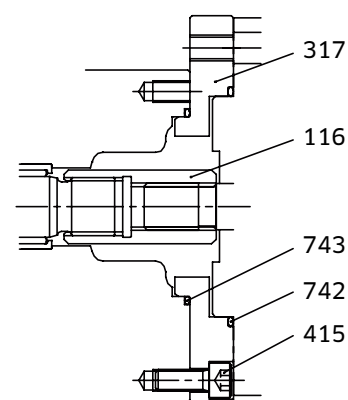

SAE 'B', 'BB', 'C' & 'C4' T/D Kit

NO.	Part Name	Qty	Cover Kit	SAE 'A' T/D Kit	SAE 'B' T/D Kit
-	T/D Kit	-	29L8TN	29L8TA	29L8TB
743	O-Ring	1	00RBG85	00RBG85	00RBG85
742	O-Ring	1	-	-	00RBG105
415	Screw Hex SHC	4	-	-	OSBM1025
402	Screw Hex SHC	2	OSBM1020	-	-
317	Subplate	1	-	-	2924750-0354
314	Cover	1	2923150-0316	-	-
116	Coupling	1	-	2903150-0241	2903150-0262

NO.	Part Name	Qty	SAE 'BB' T/D Kit	SAE 'C' T/D Kit	SAE 'C4' T/D Kit
-	T/D Kit	-	29L8T2	29L8TC	29L8TC4
743	O-Ring	1	00RBG85	00RBG85	00RBG85
742	O-Ring	1	00RBG105	00RBG130	00RBG130
415	Screw Hex SHC	4	OSBM1025	OSBM1030	OSBM1030
402	Screw Hex SHC	2	-	-	-
317	Subplate	1	2924750-0354	2924750-0355	2924750-0439
314	Cover	1	-	-	-
116	Coupling	1	2903150-0267	2903150-0263	2903150-0263

3-4 K3VL112/140 Installation

◆ K3VL112/140 with Cut-Off / Load Sense Control & Torque Limit Module (Clockwise Rotation)

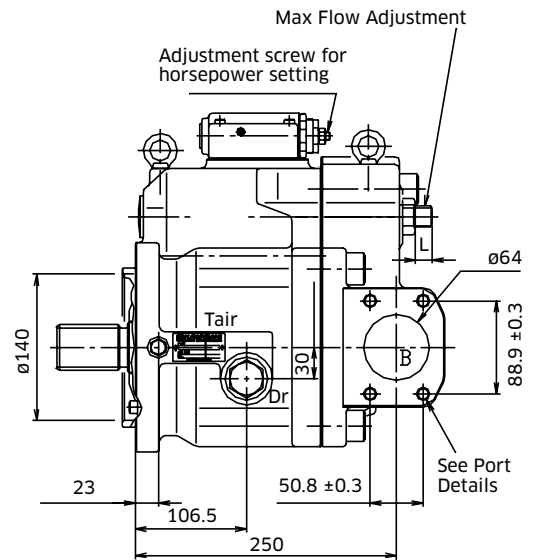
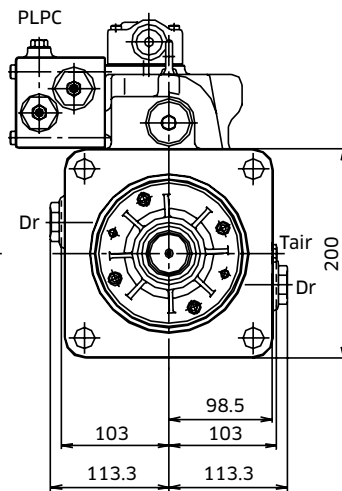
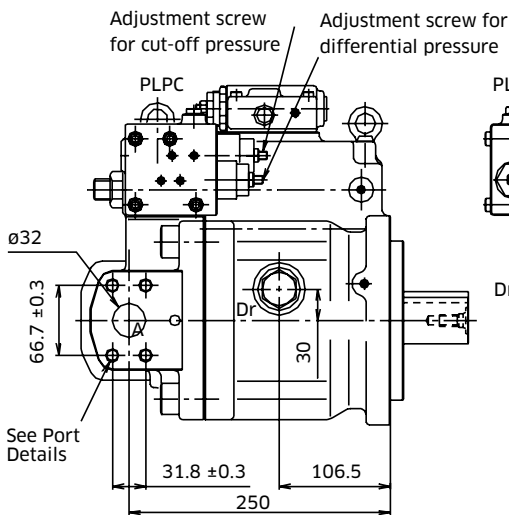
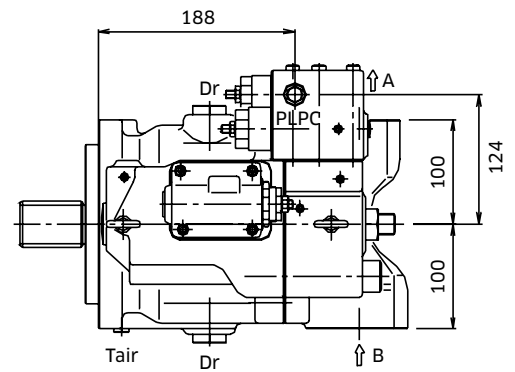
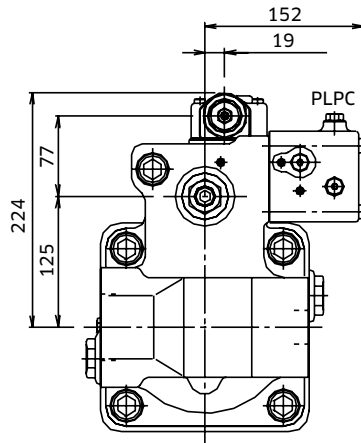

Note: for counter clockwise rotation, the suction port 'B' and the delivery port 'A' are reversed.

3-4 K3VL112/140 Installation (cont)

◆ K3VL112/140 (SAE D 4 BOLT) Mounting Flange & Shaft Options

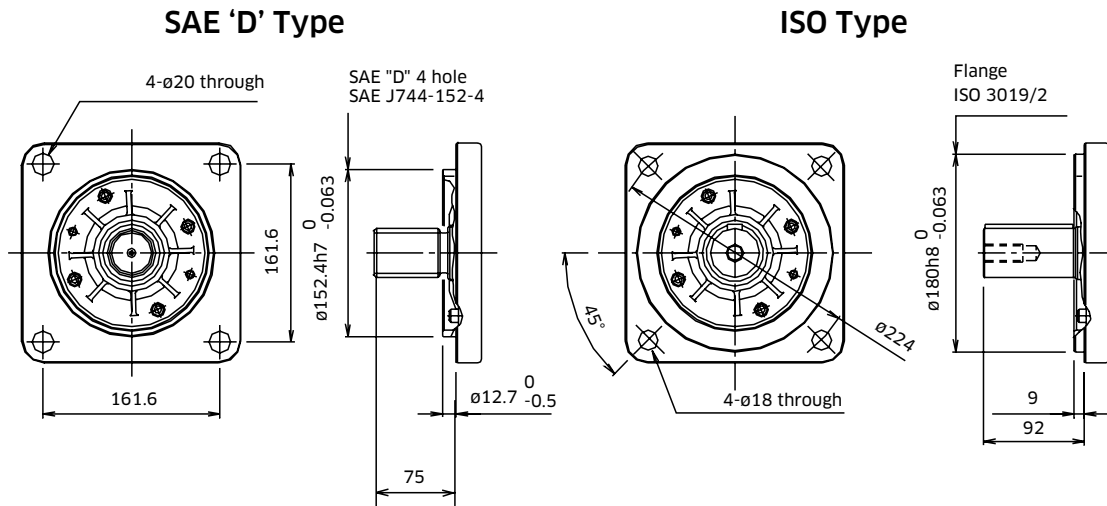

SAE 'D' Spline Shaft

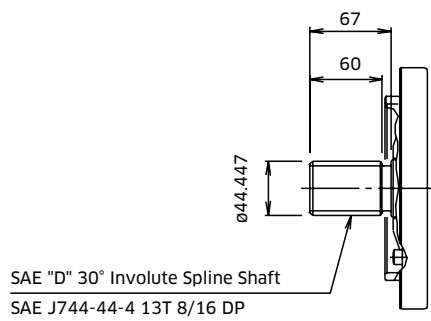

SAE 'D' Straight Shaft

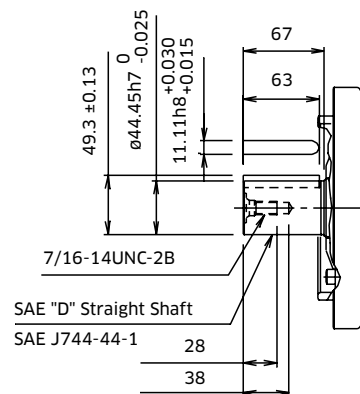

ISO Straight Shaft

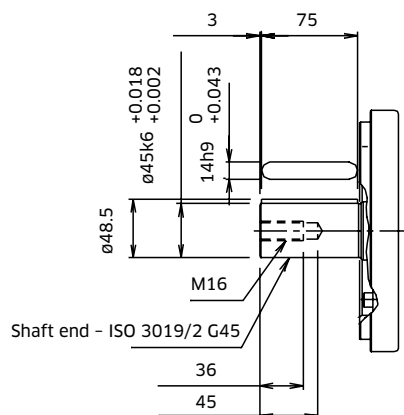

3-4 K3VL112/140 Installation (cont)

◆ K3VL112/140 Rear Port

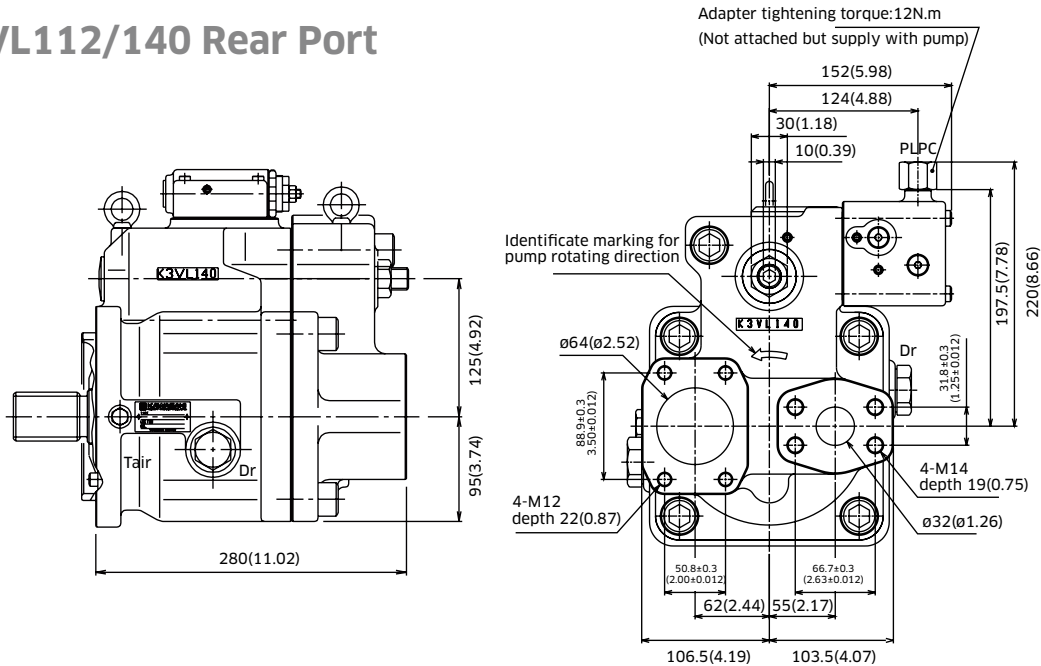

◆ K3VL112/140 Porting Details

Main SAE Flanged Ports

Des.	Port Name	Port Size	Tightening Torque (Nm)	Flange Threads
------	-----------	-----------	------------------------	----------------

UNF Threaded Version ('S' in position 9 of model code)

A	Delivery Port	SAE J518C high pressure (code 62) 1 ¼"	157	½-13UNC-2B x 22 mm
B	Suction Port	SAE J518C Std pressure (code 61) 2 ½"	98	½-13UNC-2B x 22 mm

Metric Version ('M' in position 9 of model code)

A	Delivery Port	SAE J518C high pressure (code 62) 1 ¼"	157	M14 x 19
B	Suction Port	SAE J518C Std pressure (code 61) 2 ½"	98	M12 x 17

Auxiliary Ports

Des.	Port Name	Port Size	Tightening Torque (Nm)
------	-----------	-----------	------------------------

SAE Version ('S', 'K', 'C', 'R', 'U', 'X' or 'T' in position 8 of model)

Dr	Drain Port (x2)	SAE J1926/1 Straight thread O ring boss ¾" OD Tube 1 ⅙ -12UN-2B	167
PLPC	Load Sensing Port Pressure Control Port	SAE J1926/1 Straight thread O ring boss ¼" OD Tube ⅞ -20UNF-2B	12
Tair	Air Bleeder Port	SAE J1926/1 Straight thread O ring boss ¼" OD Tube ⅞ -20UNF-2B	12

ISO Version ('M' in position 8 of model code)

Dr	Drain Port (x2)	M27 x 2 DIN 3852	167
PLPC	Load Sensing Port Pressure Control Port	M14 x 1.5 DIN 3852	25
Tair	Air Bleeder Port	M14 x 1.5 DIN 3852	25

3-4 K3VL112/140 Installation (cont)

◆ K3VL112/140 (2 Bolt) Installation

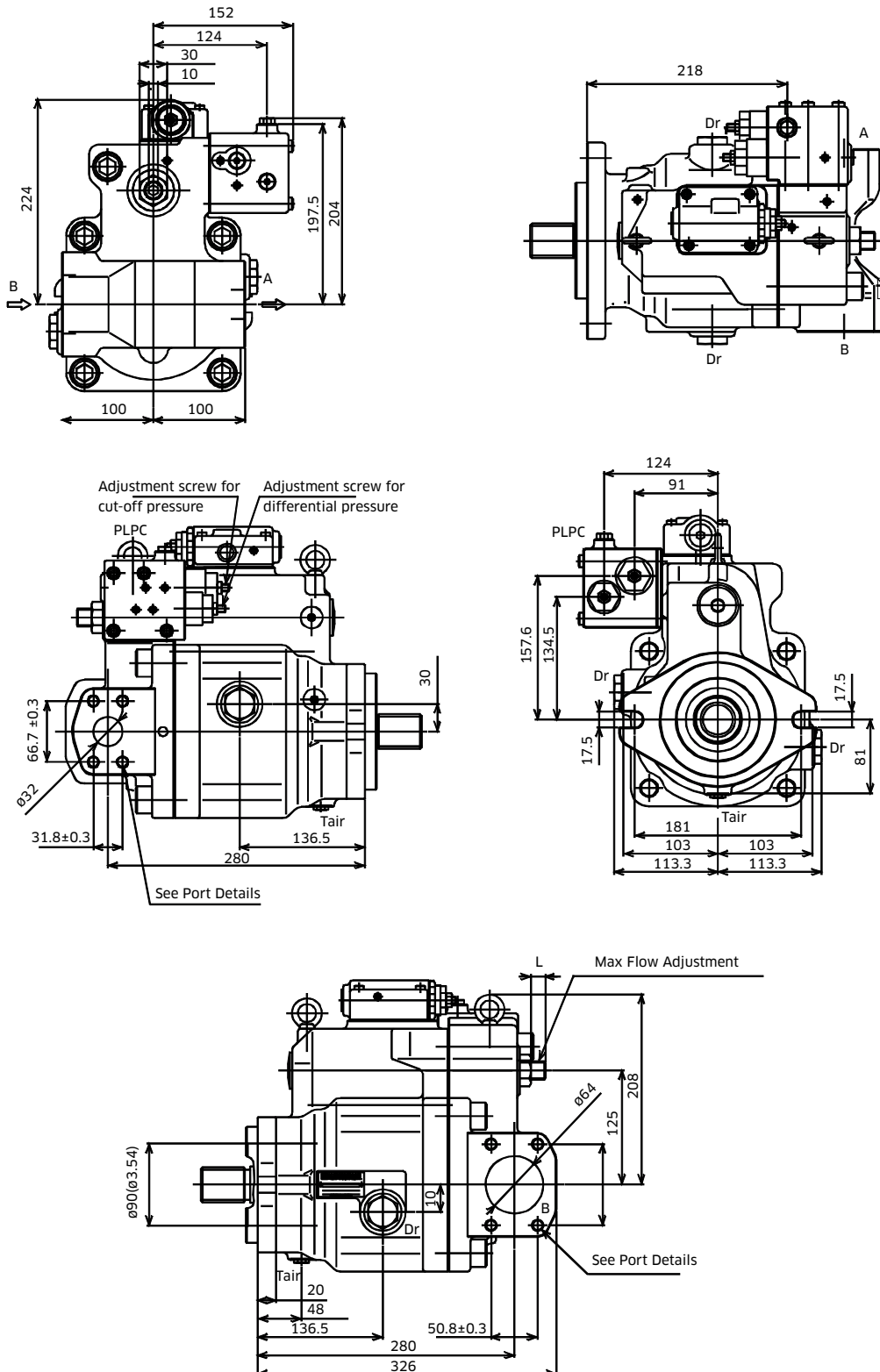

3-4 K3VL112/140 Installation (cont)

◆ K3VL112/140 Mounting Flange (2 Bolt) and Shaft Options

SAE 'C' Type

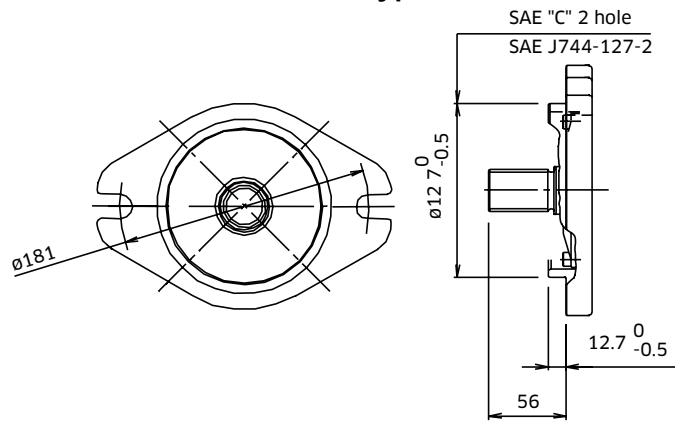

SAE 'C' Spline Shaft

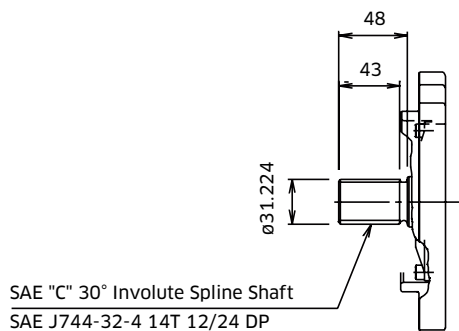

SAE 'C' Straight Shaft

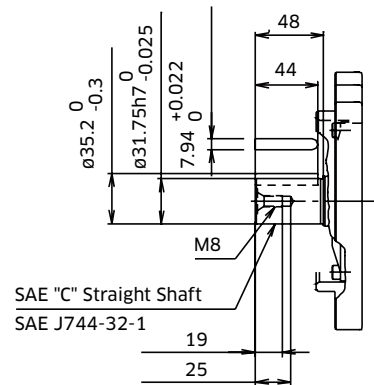

SAE 'CC' Spline Shaft

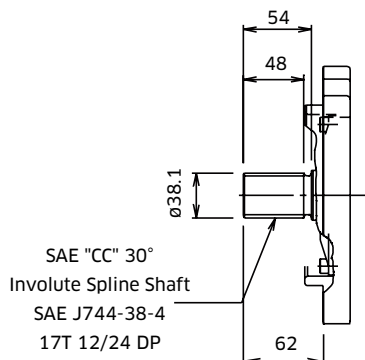

SAE 'CC' Straight Shaft

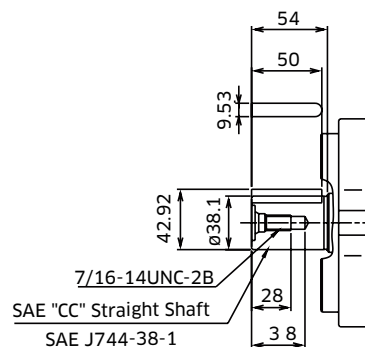

3-4 K3VL112/140 Installation (cont)

◆ K3VL112/140 Through Drive Options

Through Drive 'A'

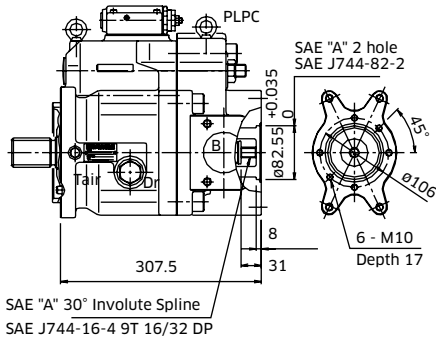

Through Drive 'B'

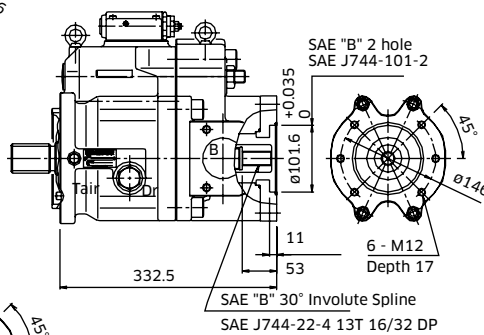

Through Drive 'BB'

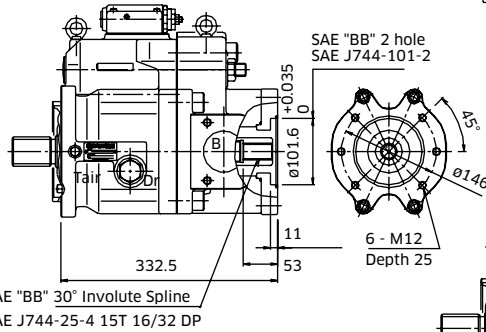

Through Drive 'C'

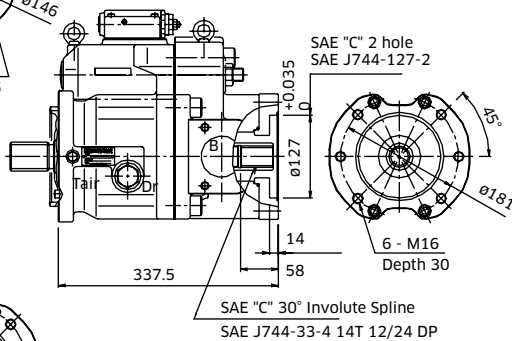

Through Drive 'C4'

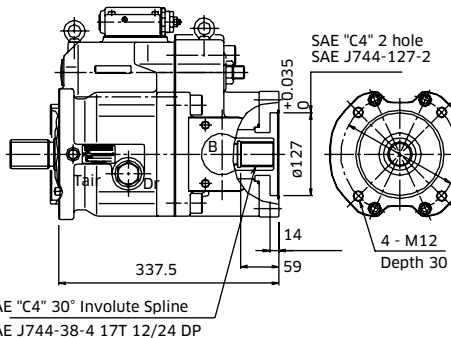

Through Drive 'CC'

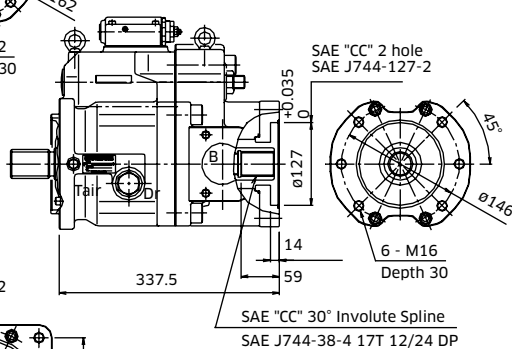

Through Drive 'D'

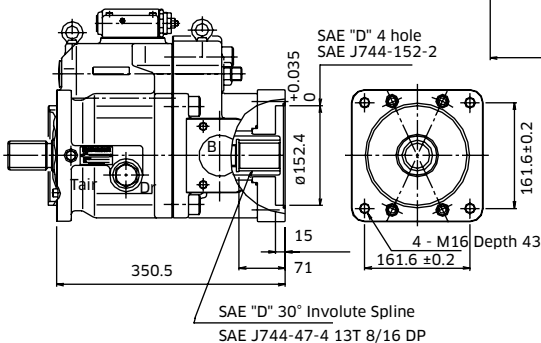

3-4 K3VL112/140 Installation (cont)

◆ K3VL112/140 Adaptor Kits

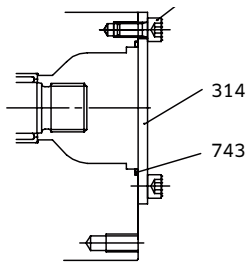

COVER KIT

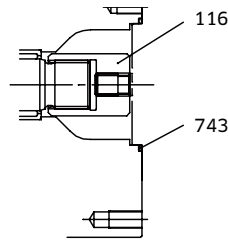

SAE 'A' T/D KIT

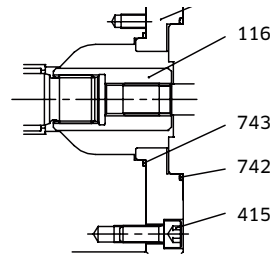

SAE 'B' T/D KIT

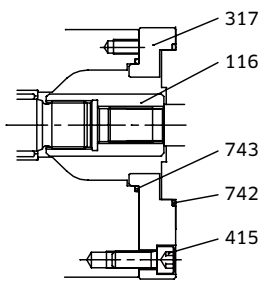

SAE 'BB' T/D KIT

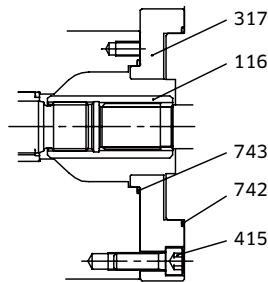

SAE 'C' & 'C4' T/D KIT

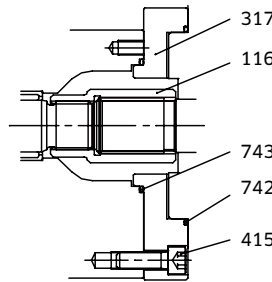

SAE 'CC' T/D KIT

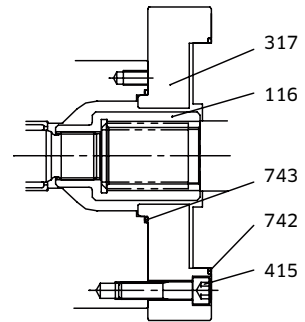

SAE 'D' T/D KIT

NO.	Part Name	Qty	Cover Kit	SAE 'A' T/D Kit	SAE 'B' T/D Kit	SAE 'BB' T/D Kit
-	T/D Kit	-	29L8TN	29LHTA	29LHTB	29LHT2
743	O-Ring	1	OORBG85	OORBG85	OORBG85	OORBG85
742	O-Ring	1	-	-	OORBG105	OORBG105
415	Screw Hex SHC	4	-	-	OSBM1230	OSBM1230
402	Screw Hex SHC	2	OSBM1020	-	-	-
317	Subplate	1	-	-	2924750-0360	2924750-0360
314	Cover	1	2923150-0316	-	-	-
116	Coupling	1	-	2903150-0268	2903150-0269	2903150-0270

NO.	Part Name	Qty	SAE 'C' T/D Kit	SAE 'C4' T/D Kit	SAE 'CC' T/D Kit	SAE 'D' T/D Kit
-	T/D Kit	-	29LHTC	29LHT4	29LHT3	29LHTD
743	O-Ring	1	OORBG85	OORBG85	OORBG85	OORBG85
742	O-Ring	1	OORBG130	OORBG130	OORBG130	OORBG150
415	Screw Hex SHC	4	OSBM1235	OSBM1235	OSBM1235	OSBM1250
402	Screw Hex SHC	2	-	-	-	-
317	Subplate	1	2924750-0361	2924750-0603	2924750-0361	2924750-0362
314	Cover	1	-	-	-	-
116	Coupling	1	2903150-0271	2903150-0272	2903150-0272	2903150-0273

3-5 K3VL200 Installation

◆ K3VL200 with Cut-Off / Load Sense Control & Torque Limit Module (Clockwise Rotation)

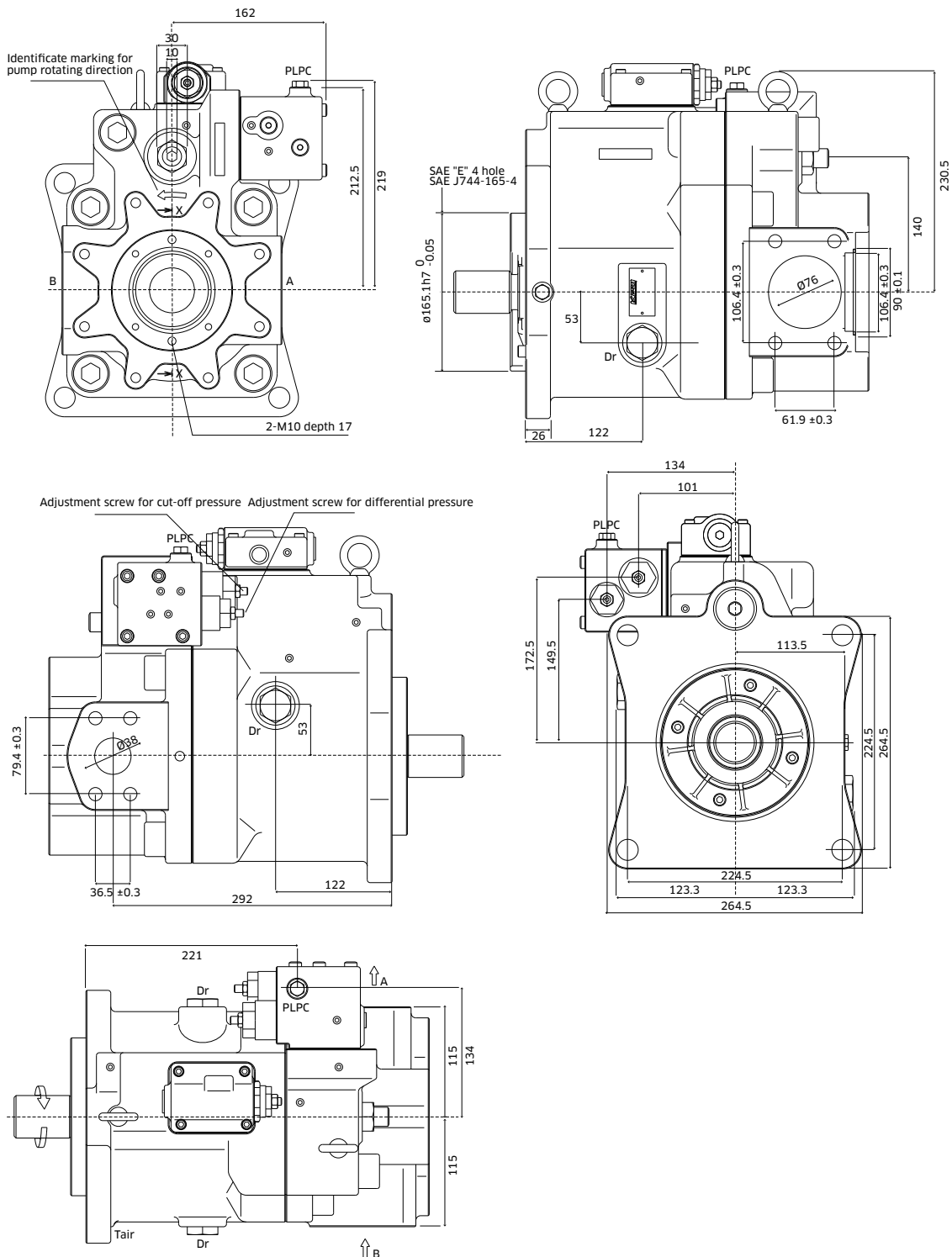

3-5 K3VL200 Installation (cont)

◆ K3VL200 Mounting Flange and Shaft Options

SAE Type

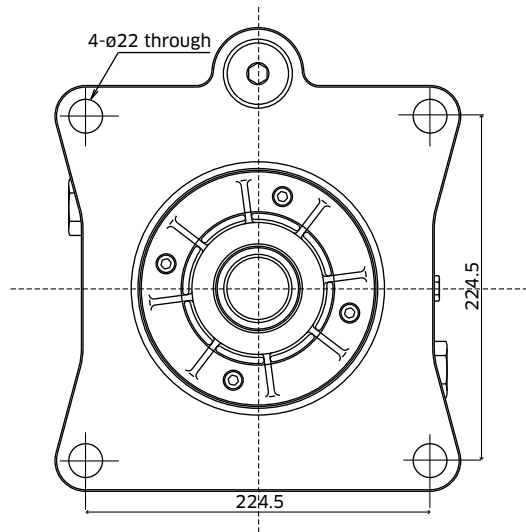

SAE Spline 'D' Shaft

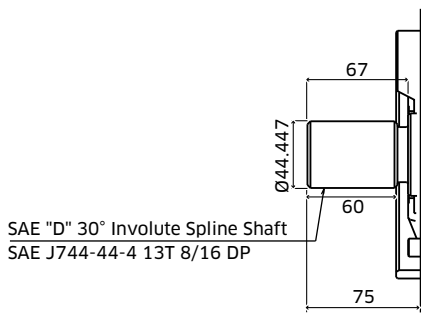

SAE 'D' Straight Shaft

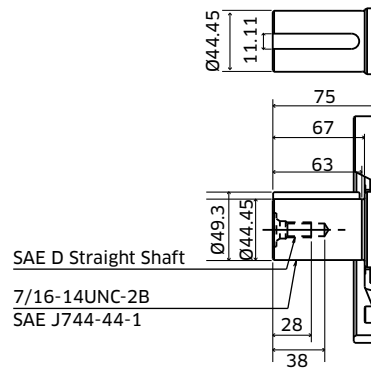

SAE Spline 'F' Shaft

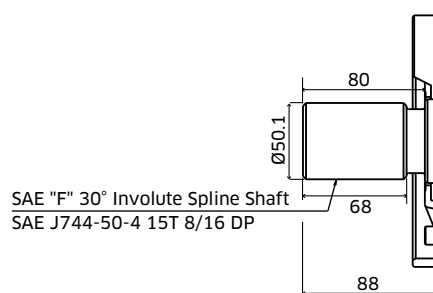

3-5 K3VL200 Installation (cont)

◆ K3VL200 Mounting Flange and Shaft Options

Through Drive 'A'

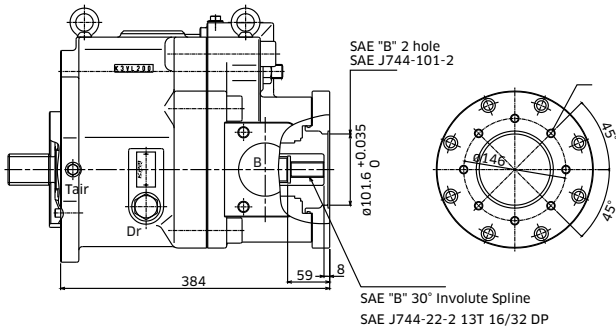

Through Drive 'C'

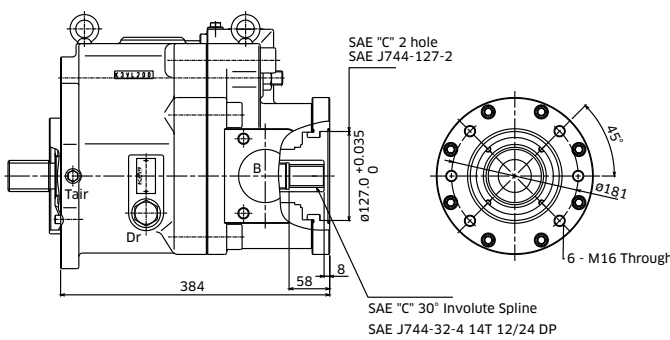

Through Drive 'CC'

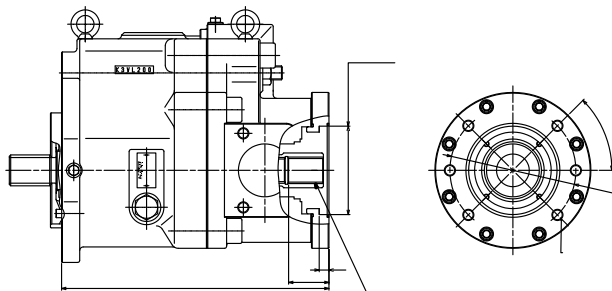

Through Drive 'E'

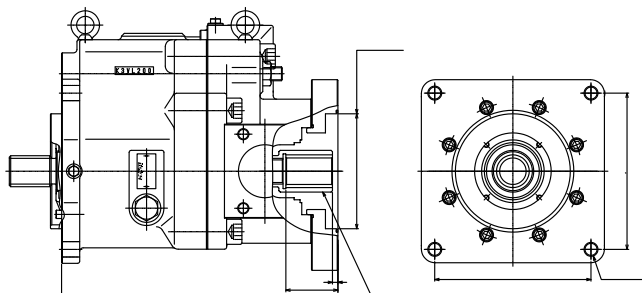

Through Drive 'A'

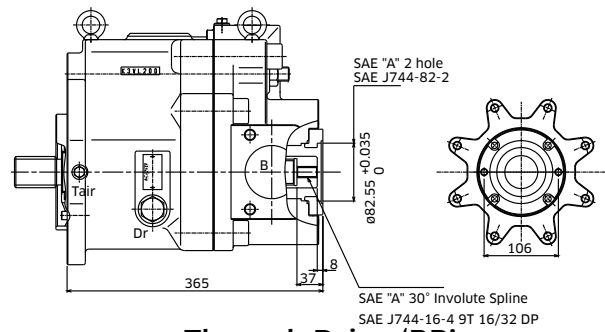

Through Drive 'BB'

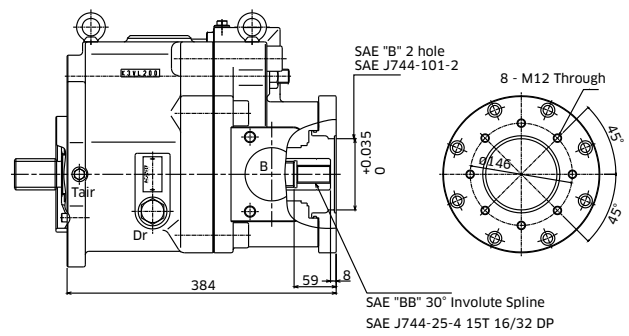

Through Drive 'C4'

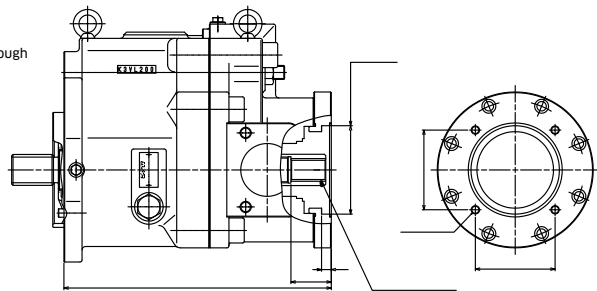

Through Drive 'D'

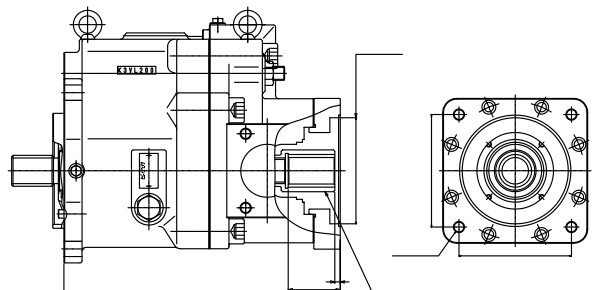

3-5 K3VL200 Installation (cont)

◆ K3VL200

NO.	Part Name	Qty	SAE 'A'	SAE 'B'	SAE 'BB'	SAE 'C'
-	T/D Kit	-	29LKTA	29LKTB	29LKT2	29LKTC
116	Coupling K3VL 200	1	2903150-0761	2903150-0762	2903150-0804	2903150-0763
317	Sub Plate K3VK 200	1	2924750-0674	2924750-0675	2924750-0675	2924750-0667
407	SHCS	8	(4 off) OSBM825	OSBM1230	OSBM1230	OSBM1230
743	O-Ring	1	OSBM85	00RBG120	00RBG120	00RBG125
742	O-Ring	1	00RBG85	00RBG105	00RBG105	00RBG130

NO.	Part Name	Qty	SAE 'C4'	SAE 'CC'	SAE 'D'	SAE 'E'
-	T/D Kit	-	29LKTC4	29LKT3	LKTD	29LKTE
116	Coupling K3VL 200	1	2903150-0763	2903150-0805	2903150-0764	2903150-0764
317	Sub Plate K3VK 200	1	2924750-0677	2924750-0667	2924750-0677	2924750-0686
407	SHCS	8	OSBM1230	OSBM1230	OSBM1245	OSBM1245
743	O-Ring	1	00RBG125	00RBG125	00RBG125	00RBG125
742	O-Ring	1	00RBG130	00RBG130	PCPP155	PCPP170

Main SAE Flanged Ports

Des.	Port Name	Port Size	Tightening Torque (Nm)	Flange Threads
------	-----------	-----------	------------------------	----------------

UNC Threaded Version ('S', 'K' in position 9 of model code)

A	Delivery Port	SAE J518C high pressure (code 62) 1½"	235	5/8-11UNC-2B
B	Suction Port	SAE J518C Std pressure (code 61) 3"	235	5/8-11UNC-2B

Metric Version ('M' in position 9 of model code)

A	Delivery Port	SAE J518C high pressure (code 62) 1½"	235	M16
B	Suction Port	SAE J518C Std pressure (code 61) 3"	235	M16

Auxiliary Ports

Des.	Port Name	Port Size	Tightening Torque (Nm)
------	-----------	-----------	------------------------

SAE Version ('S', 'K' in position 8 of model)

Dr	Drain Port (x2)	SAE J1926 Straight thread O ring boss ¾" O.D Tube 1 ¹ / ₁₆ -12UNF-2B	167
PLPC	Load Sensing Port Pressure Control Port	SAE J1926 Straight thread O ring boss ¼" O.D Tube 7 ⁸ / ₈ -20UNF-2B	12
Tair	Air Bleeder Port	SAE J1926 Straight thread O ring boss ¼" O.D Tube 7 ⁸ / ₈ -20UNF-2B	12

3-5 K3VL200 Installation (cont)

◆ K3VL200 Through drive kits

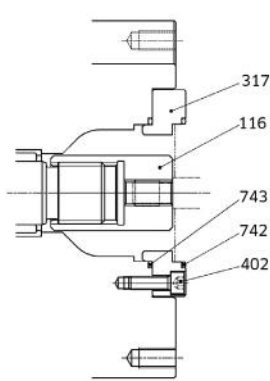

SAE "A" T/D Kit

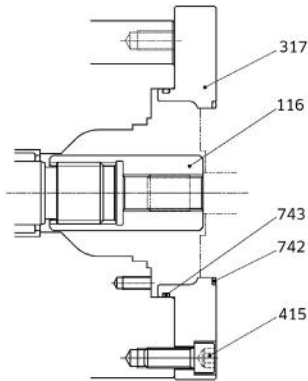

SAE "B" T/D Kit

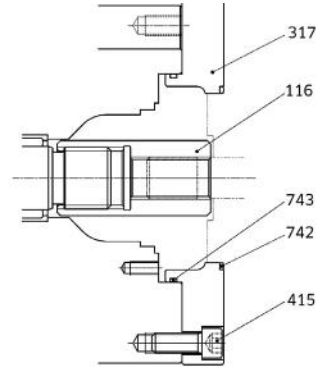

SAE "BB" T/D Kit

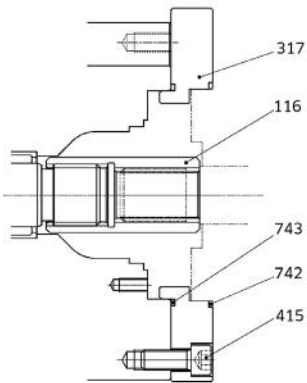

SAE "C" & "C4" T/D Kit

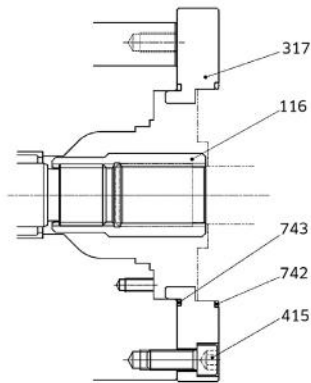

SAE "CC" T/D Kit

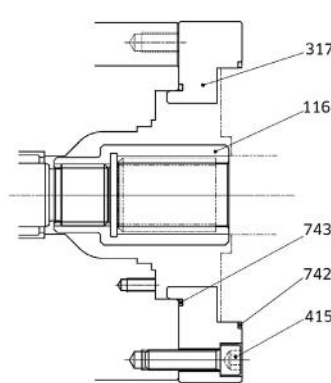

SAE "D" T/D Kit

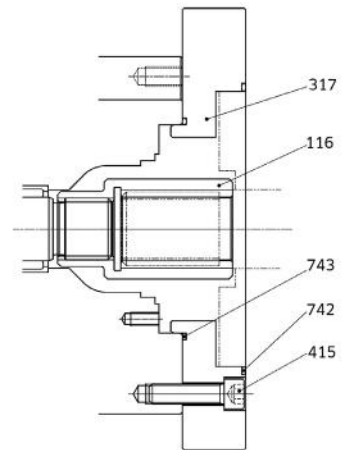

SAE "E" T/D Kit

3-6 K3VL200H Installation

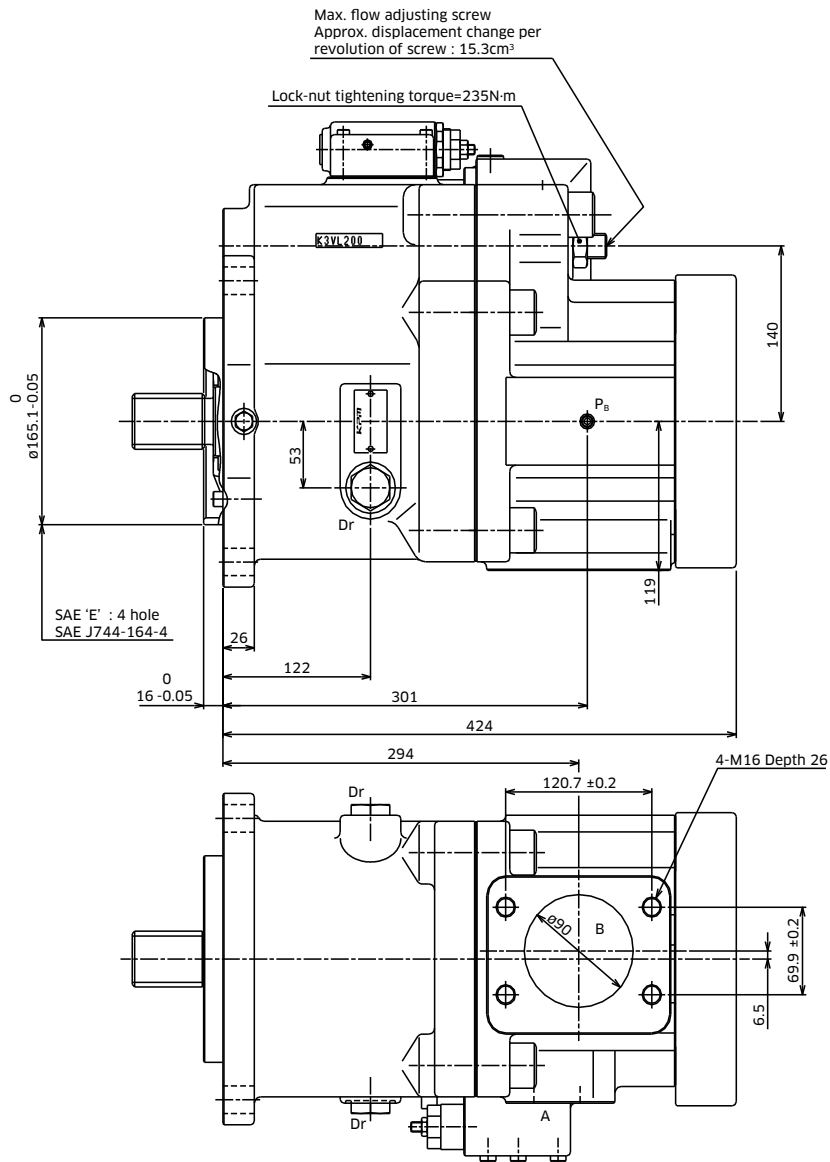

3-6 K3VL200H Installation (cont)

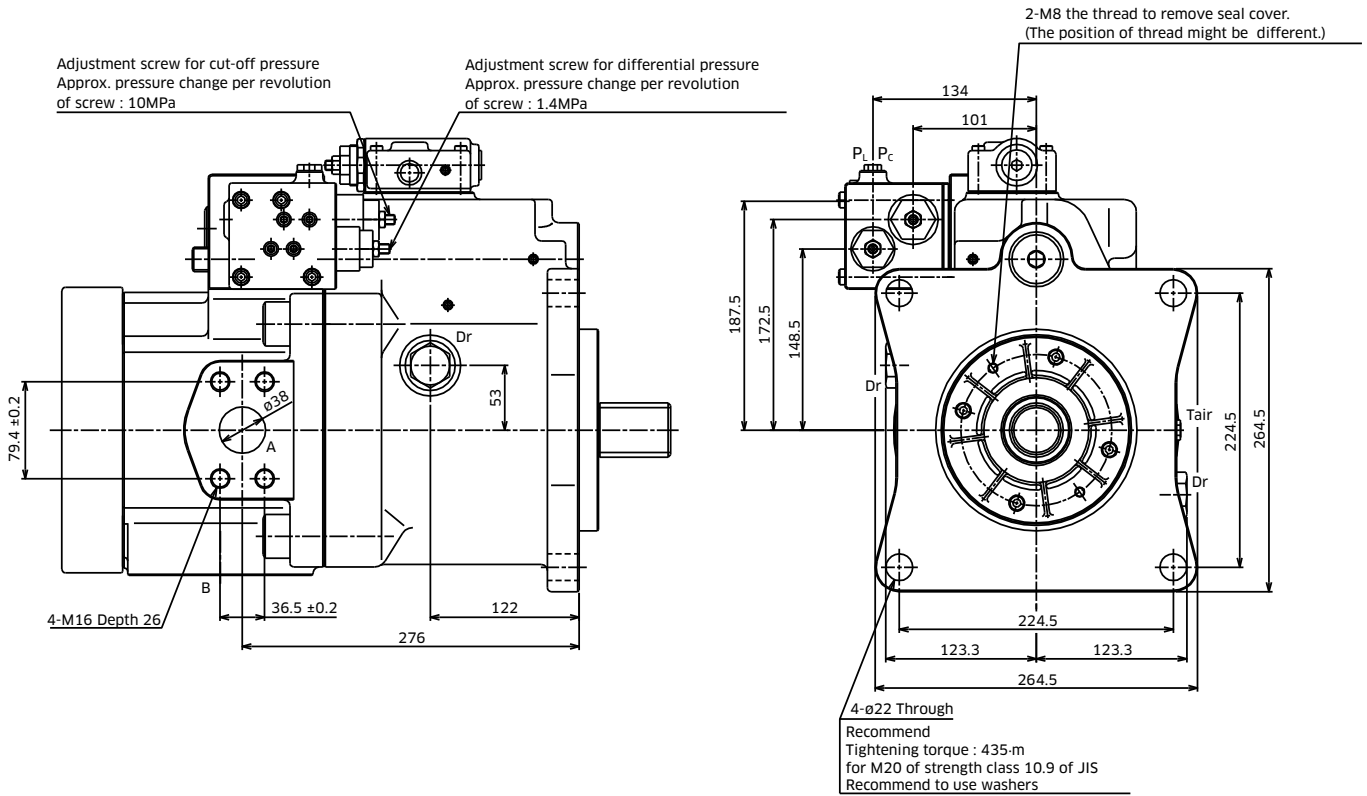

3-6 K3VL200H Installation (cont)

SAE 'B' Throughdrive

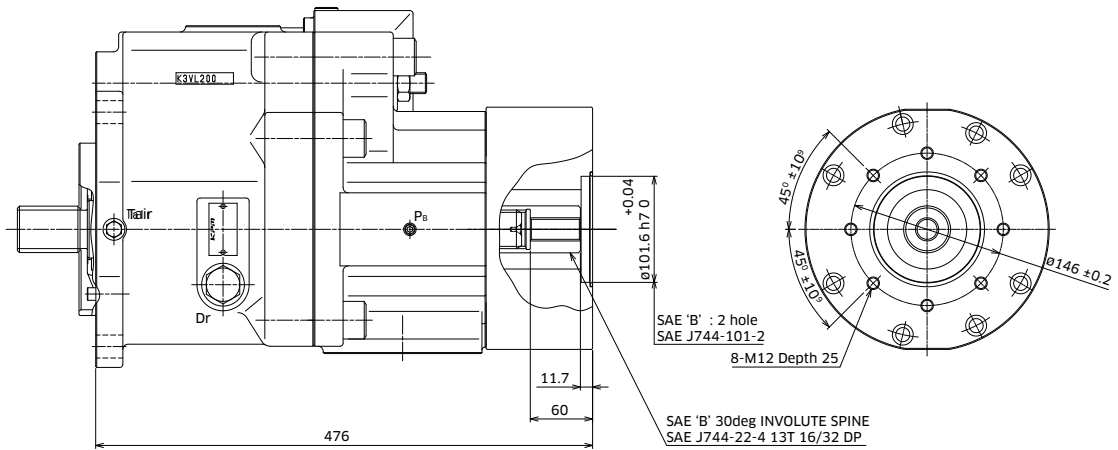

SAE 'B-B' Throughdrive

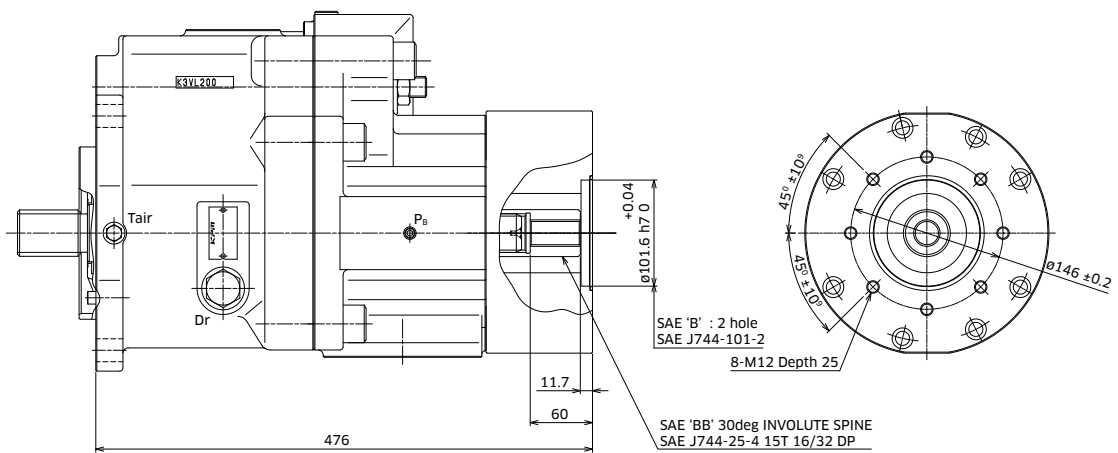

3-6 K3VL200H Installation (cont)

SAE 'C' Throughdrive

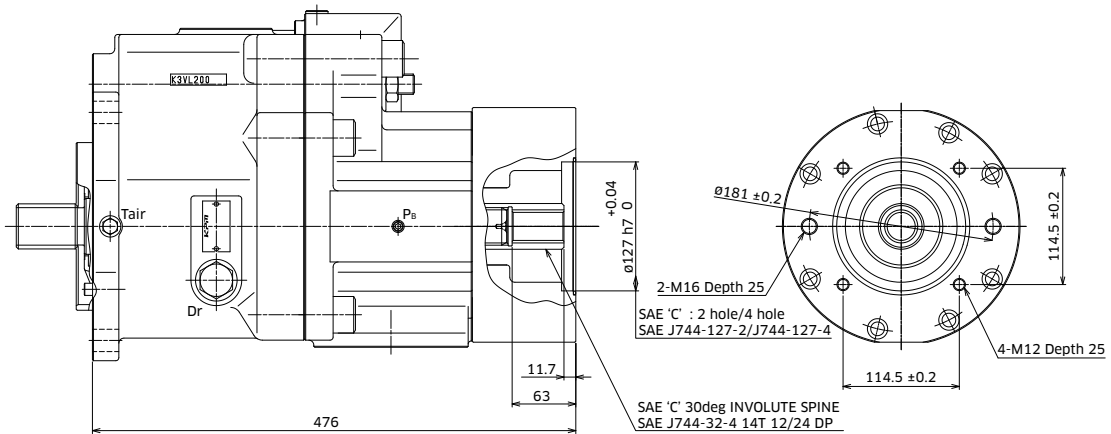

SAE 'C-C' Throughdrive

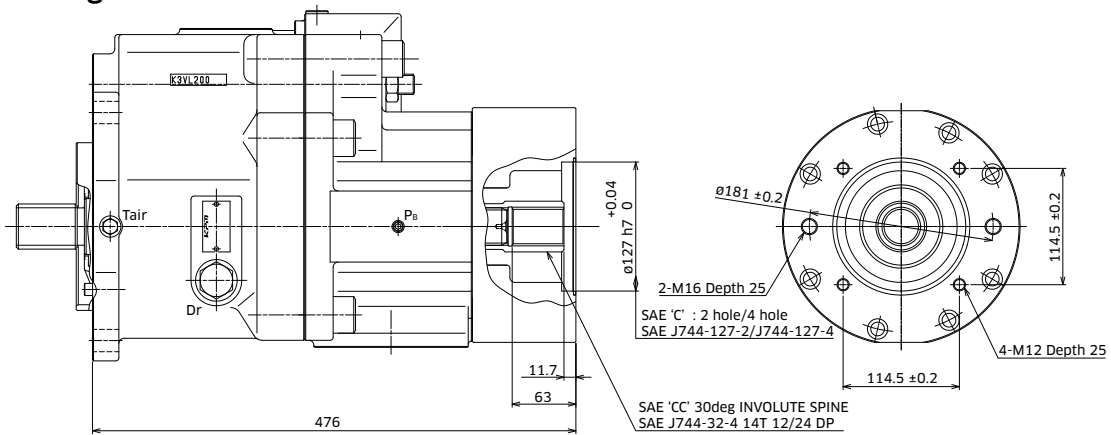

3-6 K3VL200H Installation (cont)

SAE 'D' Throughdrive

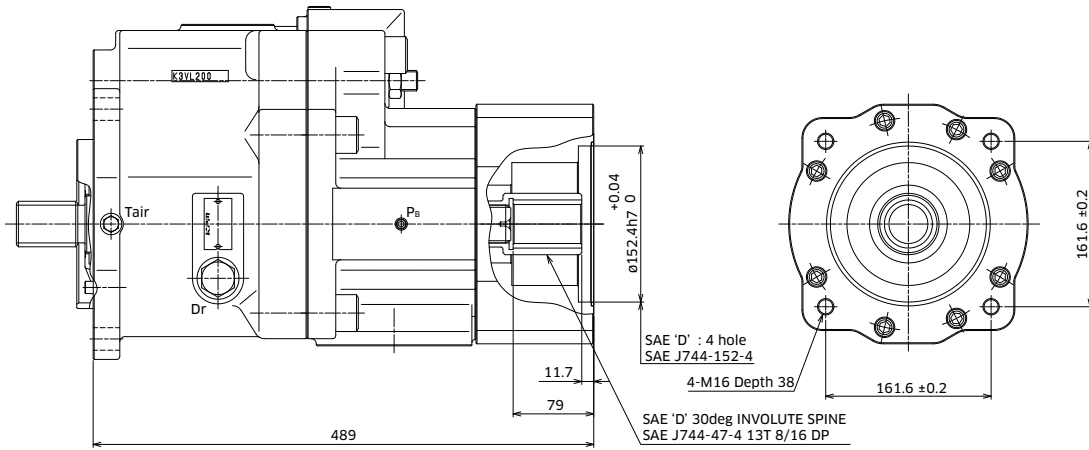

SAE 'D-D' Throughdrive

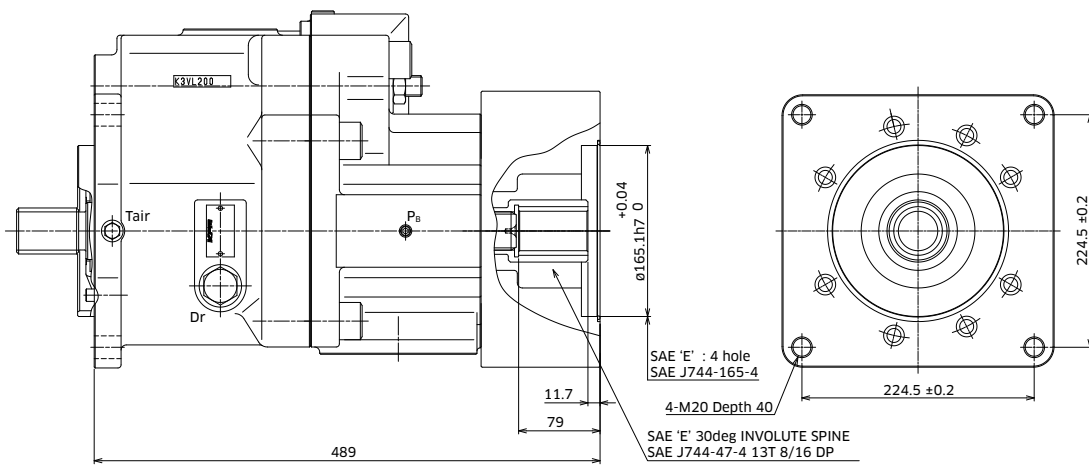

3-7 Electrical Displacement Control

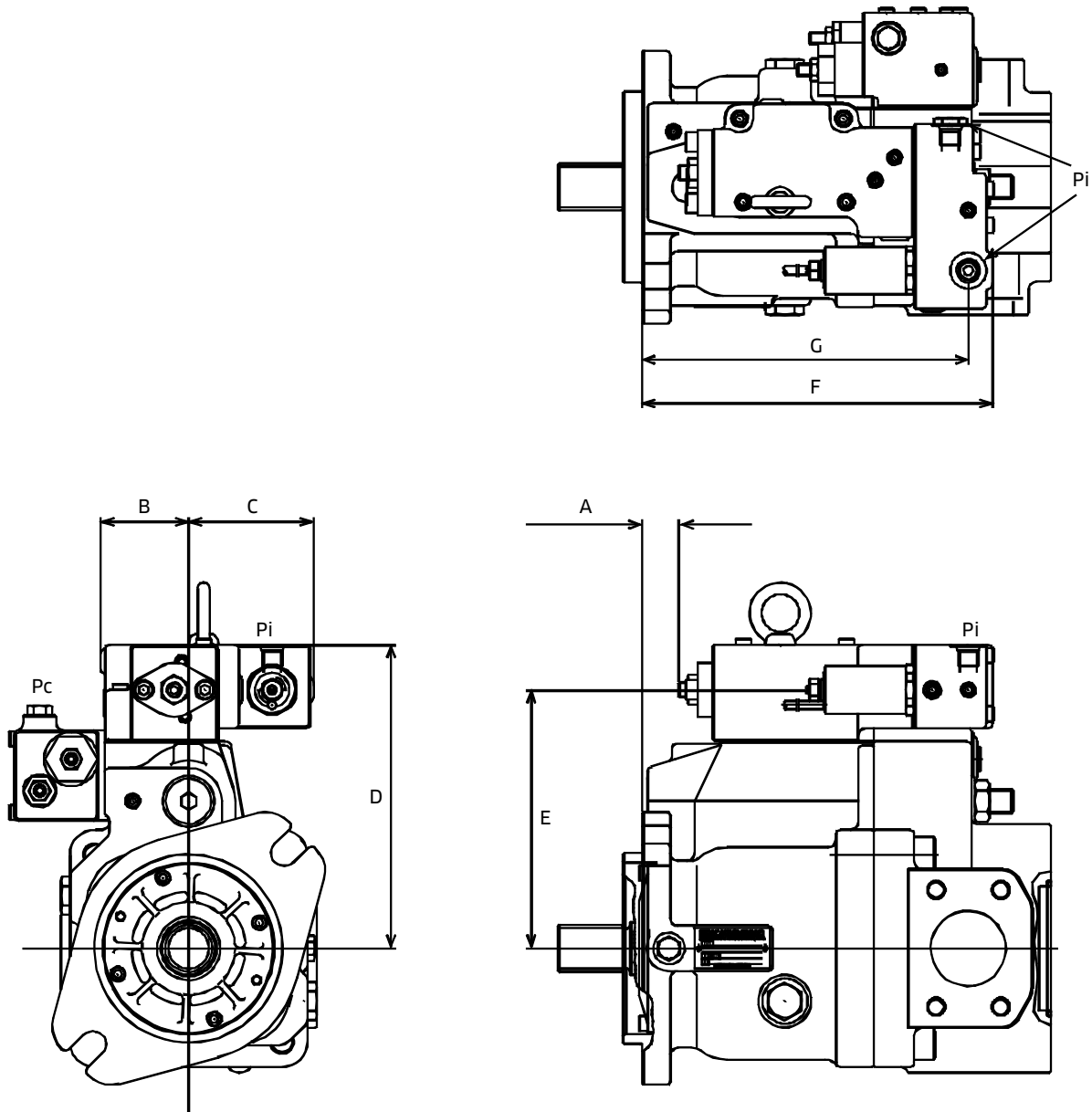

Installation Dimensions (mm)

Pump Size	A	B	C	D	E	F	G
K3VL45/60	21	52	90	187	157	226	210
K3VL80	25	59	83	202	172	233	217
K3VL112/140	38	64	78	244	214	247	231
K3VL200	57	61	80	258	229	257	249

3-7 Electrical Displacement Control (cont)

Unloading valve module (Type N,M)

Pump Size	A	B
K3VL45/60	169	155
K3VL80	169	166
K3VL112/140	202	190
K3VL200	212	205

Proportional pressure module (*V)

Pump Size	A	B
K3VL45/60	179	233
K3VL80	179	244
K3VL112/140	212	280
K3VL200	222	295

A : Distance between the centre line of the pump and the top of the bolt head for the cut off regulator.

B : Distance between the centre line of the pump and top of the solenoid valve.

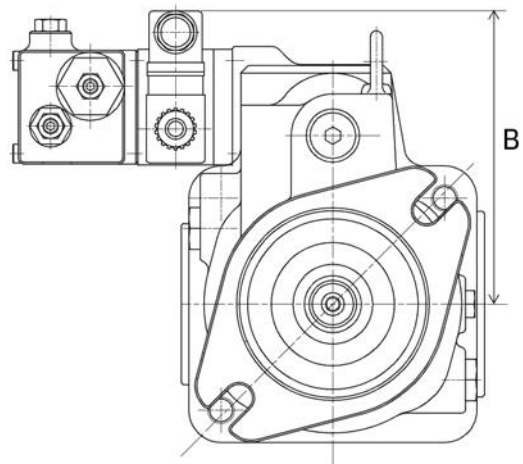
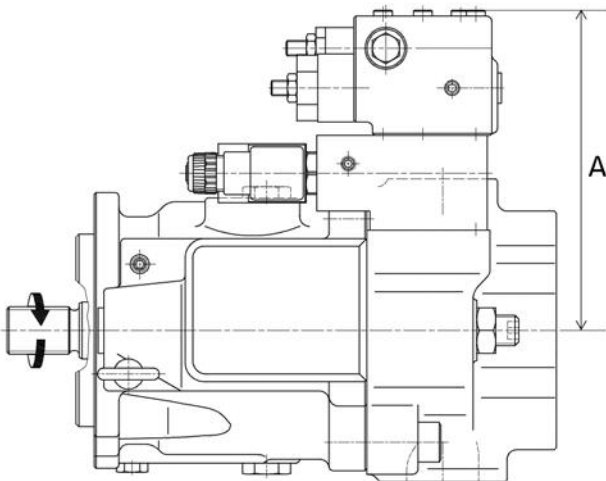

**KAWASAKI PRECISION
MACHINERY (UK) LTD**

Ernesettle, Plymouth
Devon, PL5 2SA, England

Tel: +44 1752 364394

Fax: +44 1752 364816

Mail: info@kpm-uk.co.uk

Website: www.kpm-eu.com

OTHER GLOBAL SALES OFFICES

JAPAN

Kawasaki Heavy Industry Ltd, Precision Machinery Ltd.
Tokyo Office World Trade Center Bidg.

4-1 Hamamatsu-cho

2-chome, Minato-ku

Tokyo 105-6116

Japan

Tel: +81-3-3435-6862

Website: www.khi.co.jp/kpm

U.S.A

Kawasaki Precision Machinery (U.S.A.), Inc.

3838 Broadmoor Avenue S.E.

Grand Rapids

Michigan 49512

U.S.A.

Tel: +1-616-975-3101

Website: www.kpm-usa.com

CHINA

Kawasaki Precision Machinery Trading (Shanghai) Co., Ltd.

17th Floor (Room 1701), The Headquarters Building

No168 XiZang Road (M)

Huangpu District

Shanghai 200001

China

Tel: +86-021-3366-3800

KOREA

Flutek, Ltd.

192-11, Shinchon-dong

Changwon

Kyungnam 641-370

Korea

Tel: +82-55-286-5551

Website: www.flutek.co.kr

**The specified data is for product description purposes only
and may not be deemed to be guaranteed unless expressly
confirmed in the contract.**